



Installation Manual

1968-1969 Chevelle/Malibu **Factory Air**

DOCUMENT #1-2092FA

©2018 Classic Auto Air / 12.18





Congratulations...

You have just purchased the highest quality, best performing A/C system ever designed for your Factory Air Chevelle/Malibu.

To obtain the high level of performance and dependability our systems are known for, please pay close attention to the following instructions. Our installation steps and procedures are derived from a long history of research and development and the combined experience achieved thru thousands of successful installations (and feedback from customers like you). Please remember that our #1 goal is that you'll have a successful installation and a system that performs at a very high level for many years to come.

Before starting, read the instructions carefully, from beginning to end, and follow the proper sequence. On the next page you'll find a safety and general checklist that you should read before starting your installation.

Again, thank you from our entire staff.



Check List, Pre-Installation:

- Before beginning the installation check the shipping box for the correct components. YOUR BOXED UNIT INCLUDES A LIST OF MAJOR COMPONENTS AND A LIST OF BAGGED PARTS. We have a 5 stage check process to make sure you have everything you'll need.
- If your vehicle has been or is being modified, some procedures will need to be adjusted to fit your particular application.**
- A basic cleaning of the engine compartment and interior before beginning will make things go more smoothly.
- Check condition of engine mounts. Excessive engine movement can damage hoses to A/C and/or heater.
- Before starting, check vehicle interior electrical functions (interior lights, radio, horn, etc). Make a note of anything that does not work as it's supposed to. During the installation you might find the opportunity to repair or upgrade non-working or out of date components. When you're ready to start the installation, **DISCONNECT THE BATTERY FIRST.**
- Drain the radiator. Retain the coolant and reuse, or dispose of properly.
- SAFETY FIRST: Wear eye protection while drilling/cutting, deburr sharp edges, and never get in a hurry or force a part.
- Tools: Your installation only requires the basic tools everyone has in their garage, nothing exotic or specific to A/C or Heat equipment.

Procedures, During Installation:

- Fittings: Use one or two drops of mineral oil (supplied with your kit) on ALL rubber o-rings, threads and rear of bump for o-ring where female nut rides. Do not use thread tape or sealants.
- Measure twice (or more), cut once
- Should you have any technical questions, or feel you have defective components (or missing items), call us immediately, we will be glad to assist you. Our toll-free number is listed on every page, we're here to help!**

YOU CAN NOW BEGIN THE INSTALLATION...

A Basic Overview of Automotive A/C....

- 1 Evaporator with Blower Fan** In order to remove the heat from the air in the vehicle, the A/C evaporator allows the refrigerant to absorb the heat from the air passing over it. The blower fan moves cool air out into the car interior.
- 2 Compressor** The compressor pumps and circulates the refrigerant through the system.
- 3 Condenser** The condenser is a heat exchanger mounted at the front of the vehicle. Heat drawn out of the interior of the car is expelled here.
- 4 Receiver/Drier** The drier not only dries refrigerant, it also filters the refrigerant and stores it under certain operating conditions.
- 5 High Pressure Switch** A pressure switch is used to shut down the system if high or low pressure is detected, basically it acts as a safety switch.

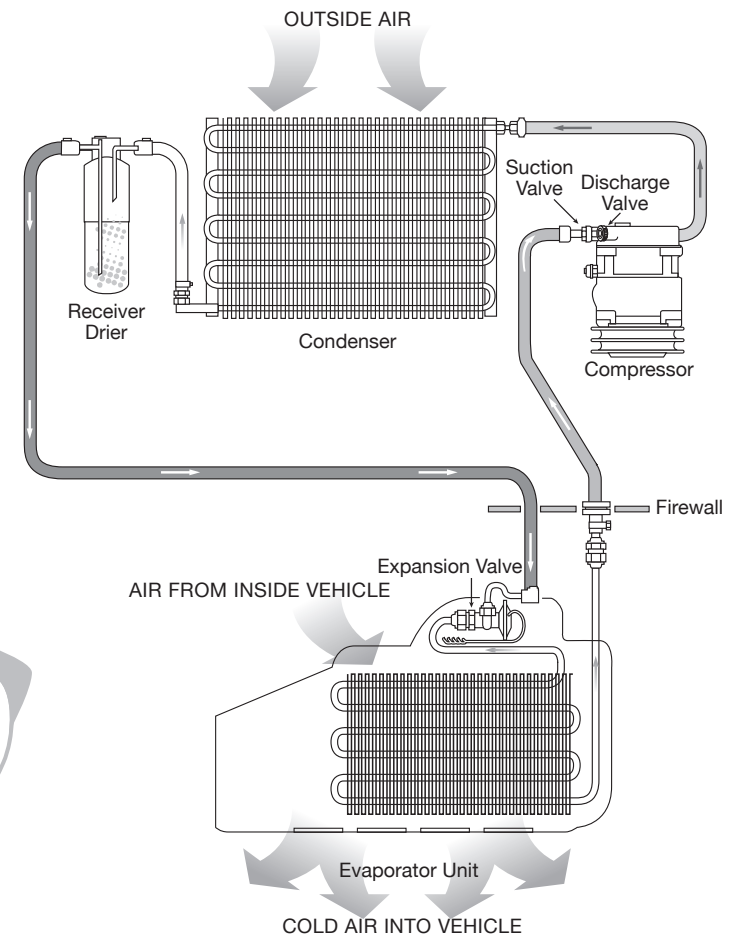
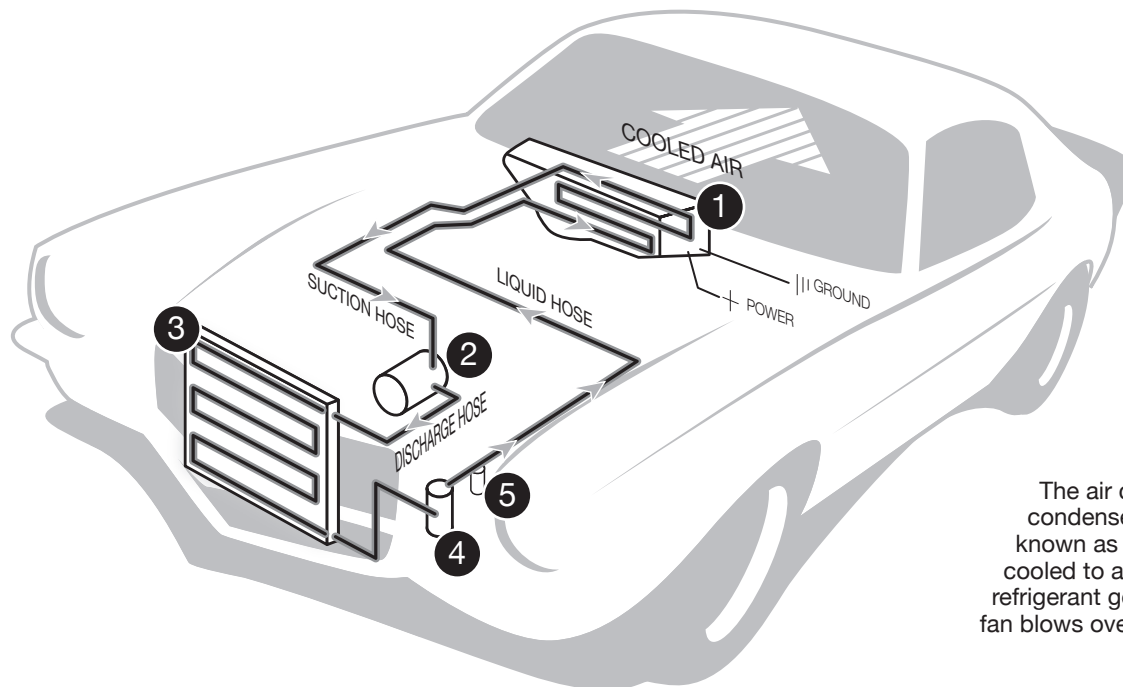

The air conditioning system in your car is comprised of a compressor, condenser, expansion valve, receiver/drier, and evaporator. Refrigerant (also known as Freon) is compressed in the compressor. In the condenser, gas is cooled to a liquid state and travels to the expansion valve. As the liquid refrigerant goes through the expansion valve it rapidly cools in the evaporator. A fan blows over the evaporator and cools the air that blows out your vents



Control & Operating Instructions

Your new Perfect Fit-Elite system offers complete comfort capabilities in virtually every driving condition. This includes temperature control in all of the modes. This system also provides the ability to blend the air between Face, Heat, and Defrost modes simultaneously. To illustrate the various ways you can adjust the airflow direction and temperature - we've provided these handy illustrations and chart to show exactly how you can adjust your Perfect Fit-Elite for maximum comfort...



The FAN switch works like the OEM switch, moving the lever away from the OFF indicator powers the system

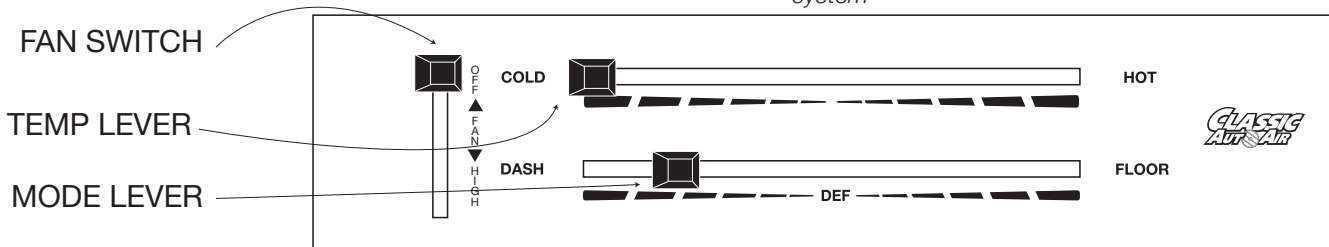

There are 11 levels of adjustment within the range of the DASH/FLOOR lever

The COLD/HOT positions works like any traditional adjustment lever

| | DASH | | | | | DEF | | | | | FLOOR |
|---------------------|---------------|--------------|--------------|--------------|--------------|--------------|-----------|-----------|-----------|-----------|------------|
| Left Lever Position | 1 | 2 | 3 | 4 | 5 | 6 | 7 | 8 | 9 | 10 | 11 |
| Distribution | Face A/C 100% | Face A/C 80% | Face A/C 60% | Face A/C 40% | Face A/C 20% | Defrost 100% | Floor 20% | Floor 60% | Floor 40% | Floor 80% | Floor 100% |
| Compressor State | ON | | | | | ON | | | | | |



Remove Glovebox, Console (if equipped), Radio OEM A/C controls and defrost duct, set aside for modification and reinstall later (see figure 1).

The removal of the Original Heater Assembly can be accomplished by disconnecting three control cables. One is attached to the Heat/Defrost door (see figure 2). One is attached to the Temperature door, and one is attached to the Vent / Heat door (see figure 3). Disconnect the electrical harness from the assembly. Also remove attachment screw located in front of the air inlet (see figure 4).

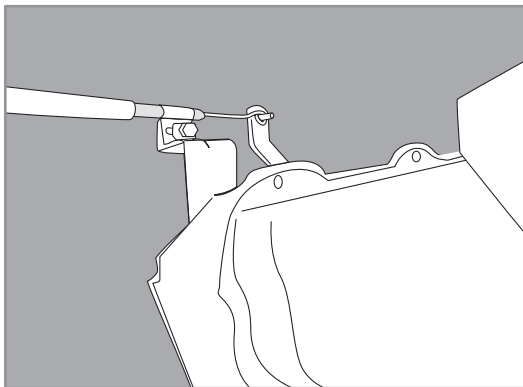
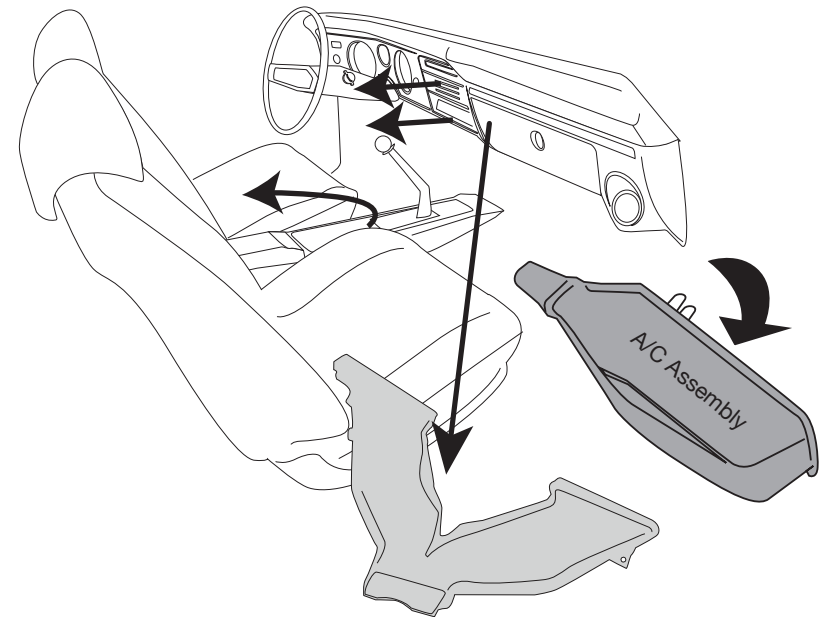

FIGURE 2

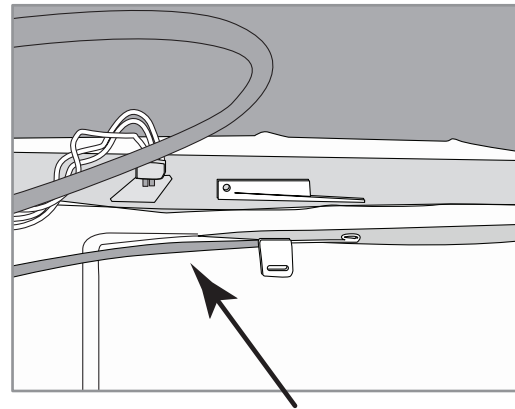

FIGURE 3

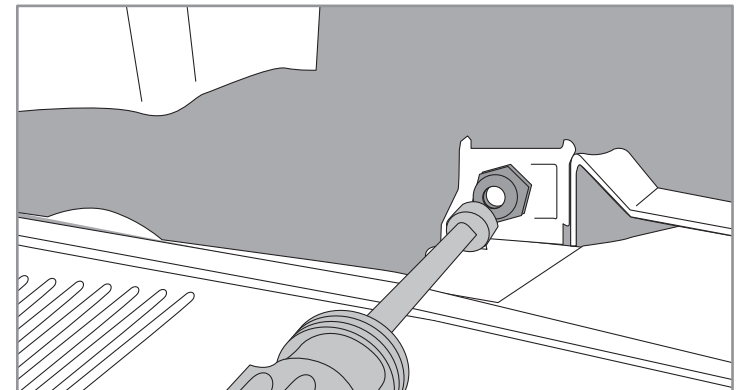
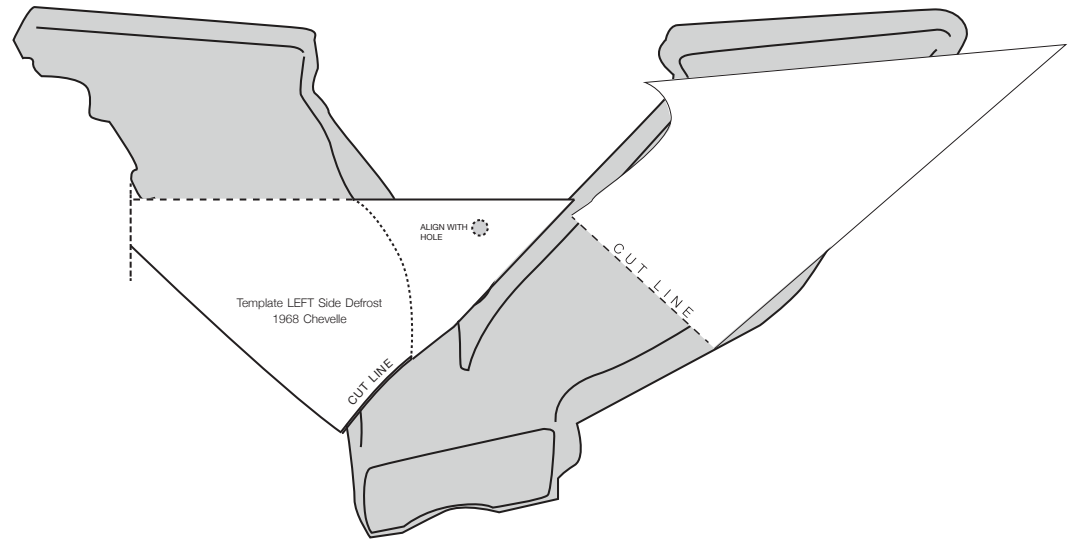

FIGURE 4

BAG KIT E: Remove defrost duct and place on a flat area like a workbench. We've included templates for modifying both sides of the duct... cut out and tape the templates in place over the duct. Cut the defrost duct into two pieces as indicated, discarding the lower half. Using the 1/4" x 1/2" open cell foam we've included, apply foam over the ends of the duct edge before installing the appropriate adapters (adapters used vary depending on year model you have). Secure the adapters with two #8 x 1/2 screws (see figure 22).



Reinstall in dash using OEM hardware.

ALERT! GM part# 3906067

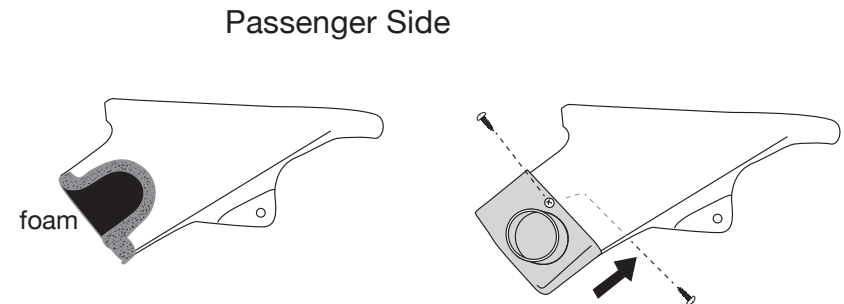
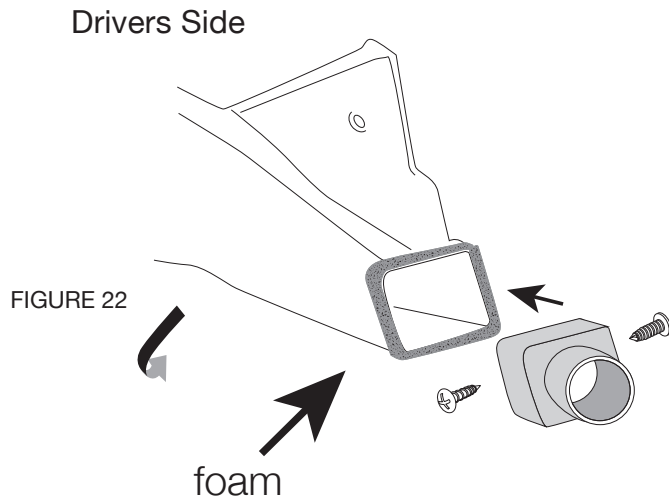

We included 2 ft. of open cell foam. Attach foam to the defrost duct as shown here. Then attach adaptor with two screws.

THESE ARE THE PARTS YOU WILL FIND IN BAG KIT A
(varies based on your choice of using your factory controls or using our new D.E.R. Controller)

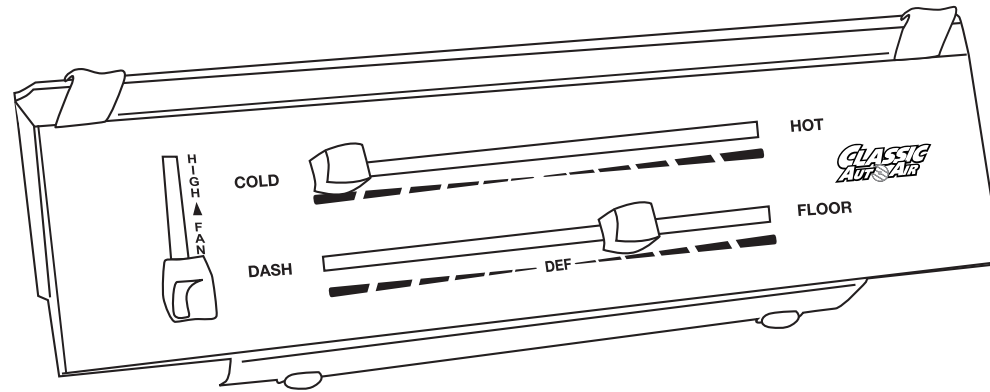

*D.E.R. Control
PN#16-3049*

NOTE: Illustrations NOT shown actual size

THESE ARE THE PARTS YOU WILL FIND IN BAG KIT B

You will use all of these parts and hardware during the next series of installation steps.



Evaporator Firewall Support Bracket
PN#0023-7

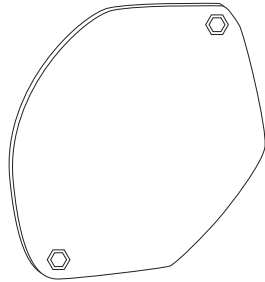

Fresh Air Inlet Block Off
PN#10-1048-2

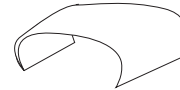

One Bulb Clamp



One Male Spade Connector

Liquid Tube
PN#0034-9

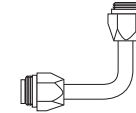

Suction Tube
PN#0034-10



#6 and #10 O-rings

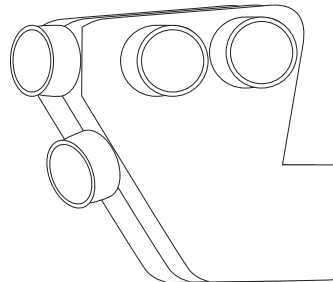

Face Duct Assembly
PN#2-2050-1
PRE-INSTALLED

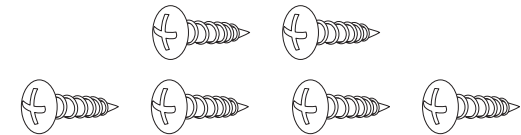

Six #10 - 10 x 5/8" Phillips Screws



Two #10 - 16 x 3/4" Tek Screws

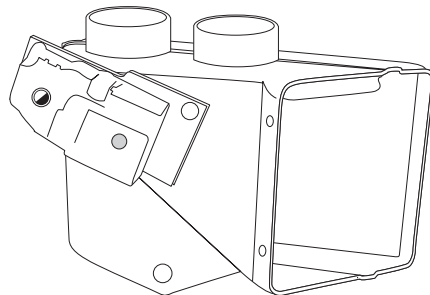

Defrost/Heat Duct Assembly
PN#2-2025-2
PRE-INSTALLED



Refrigerant Tape



Flange Nut

Illustrations NOT shown actual size

Within the engine compartment area, Install Fresh Air inlet block-off over the OEM fan opening using the original screws (it will also tuck in behind the edge of the hood hinge... tip: leave the hinge loose for now...)

Remove evaporator unit from box and place on a flat work surface.

Locate the defrost/heat duct assembly and attach to the evaporator using two #10 - 10 x 5/8" Phillips screws (see figure 16). NOTE: Be sure that the s-clips are pushed over rear flange on evaporator.

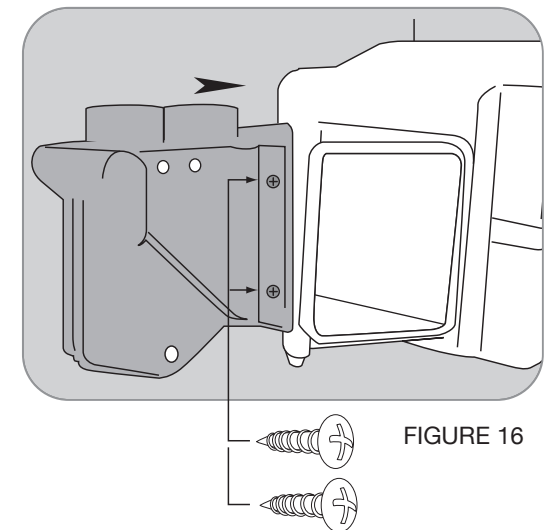
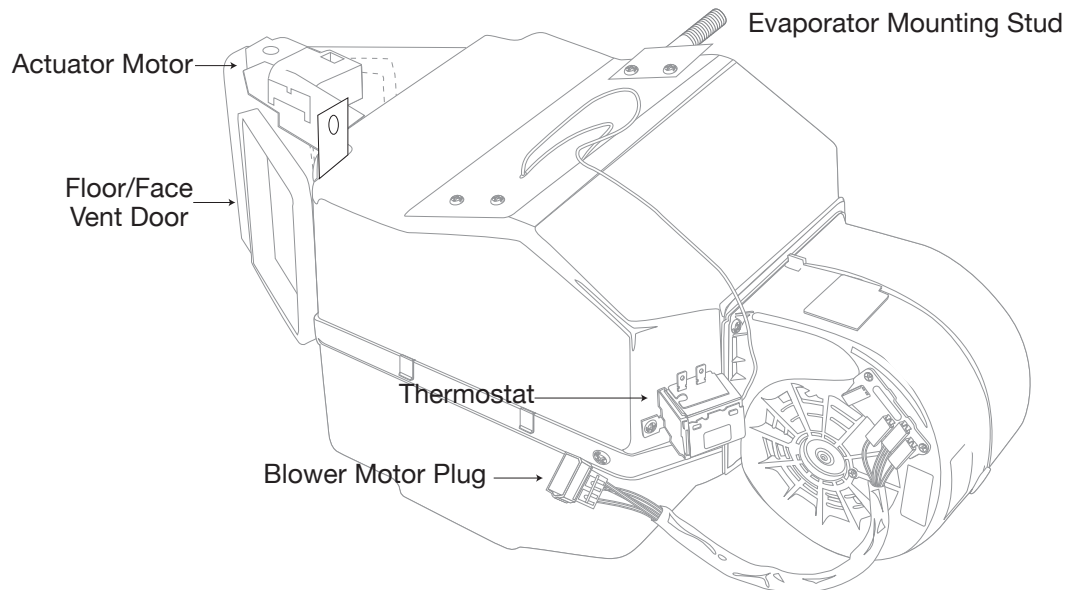
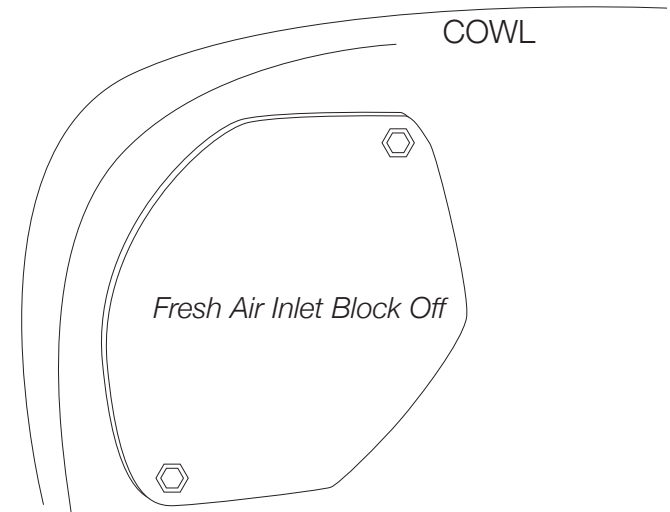

Locate recirculation door Block off assembly from Bag Kit F and Six #10-16 X 3/4" Tek screws and attach to opening in passenger kick panel.

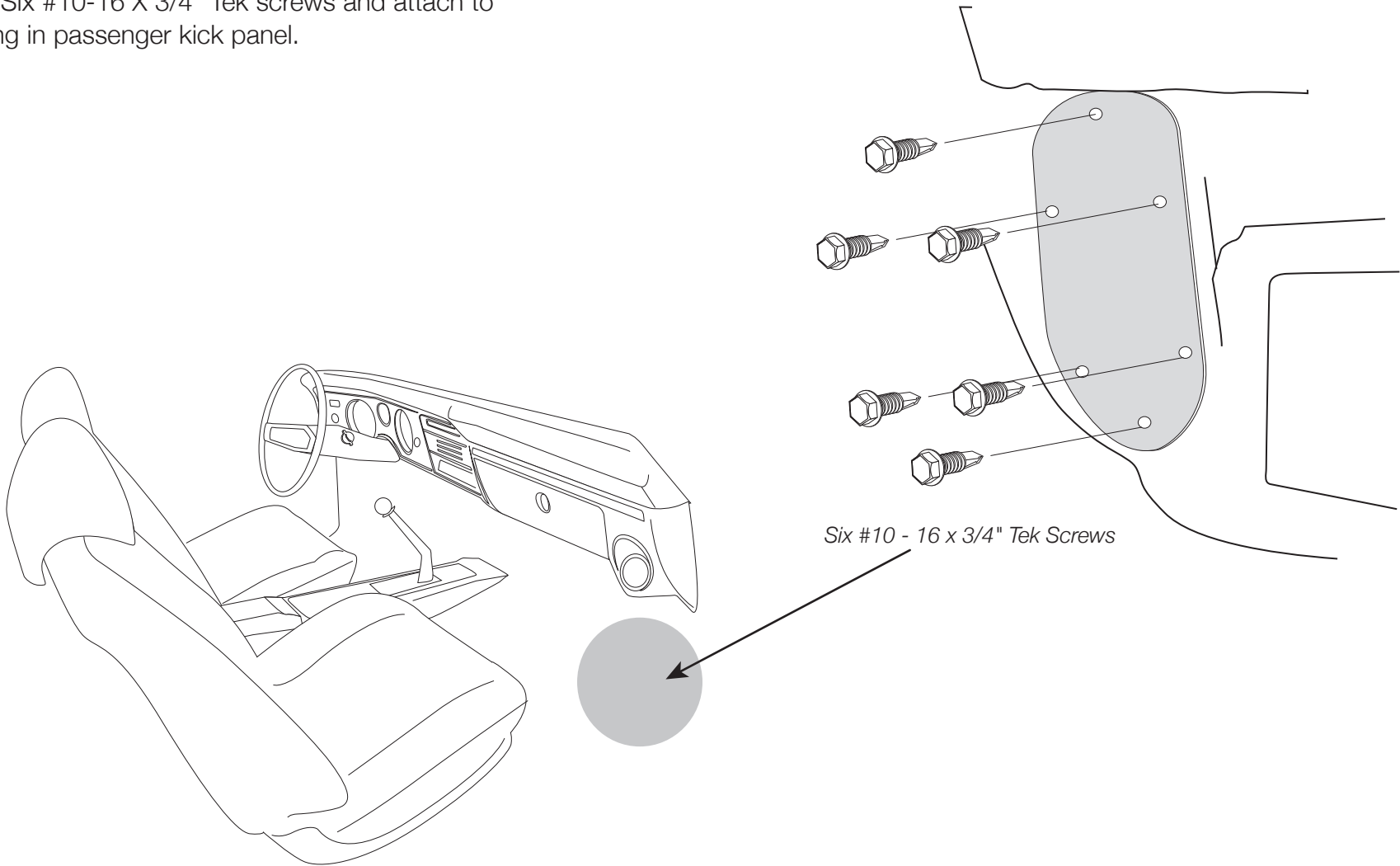

Take a minute to familiarize yourself with the evaporator unit:

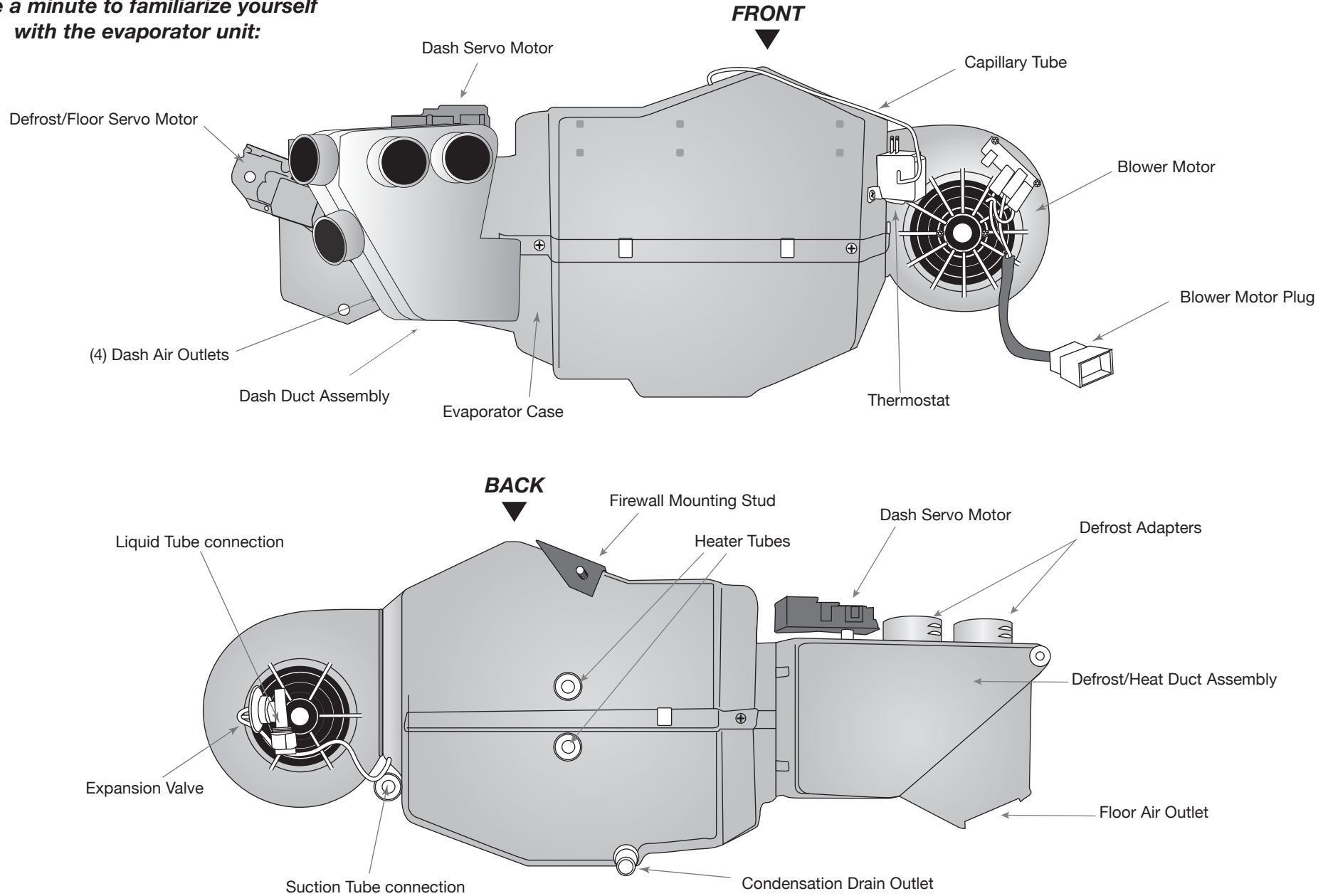

WIRING PREP

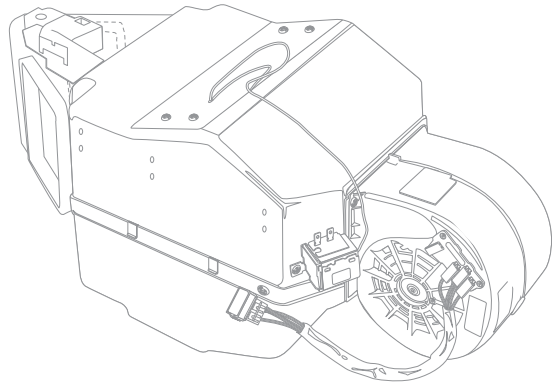

Locate Evaporator Unit from Main Box

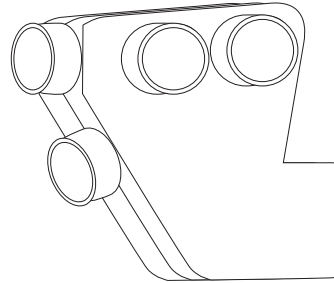

Pre-installed Face Duct Assembly

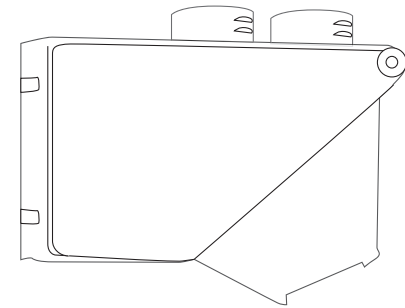

Pre-installed Defrost/Heat Duct Assembly

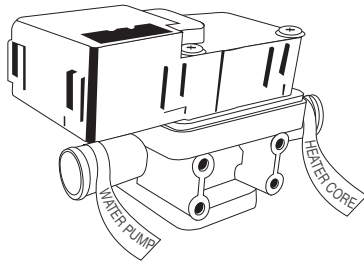

Locate electronic water valve from Bag Kit D

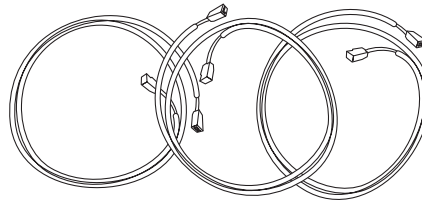

Locate Blue, Yellow, Orange wiring harness from Bag Kit C

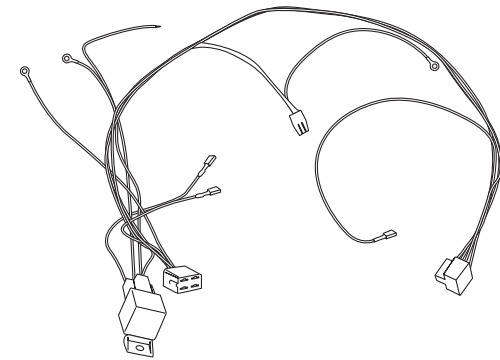

Locate main wiring harness from Bag Kit C

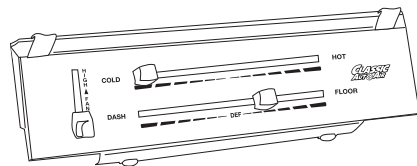

Locate the D.E.R. control in the CONTROL BOX
or modified OEM Controls

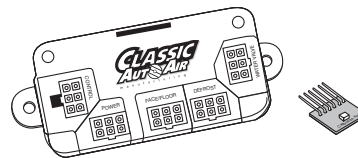

Locate ECU and Calibration Key from Bag Kit C

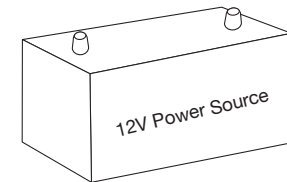

Acquire a 12V Battery (NOT a battery charger)

PRE-INSTALLED DUCT ASSEMBLIES

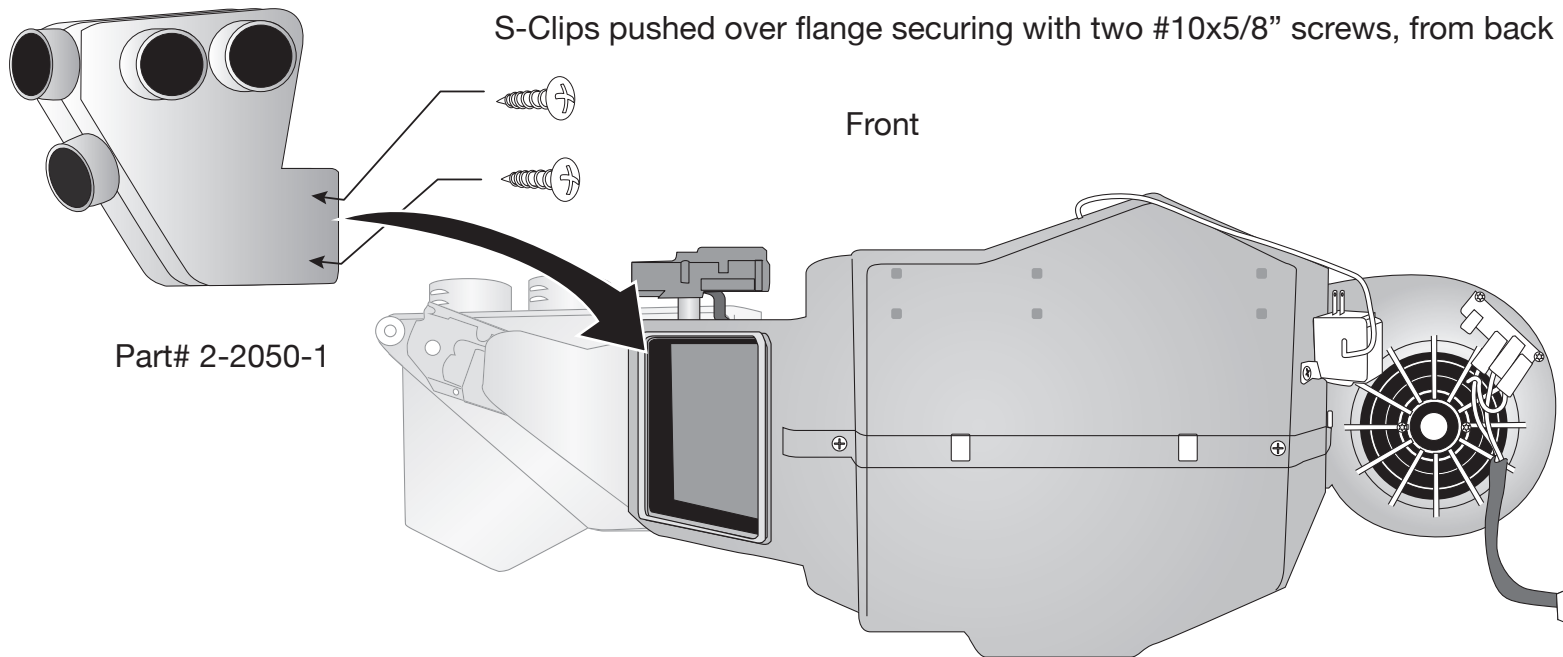
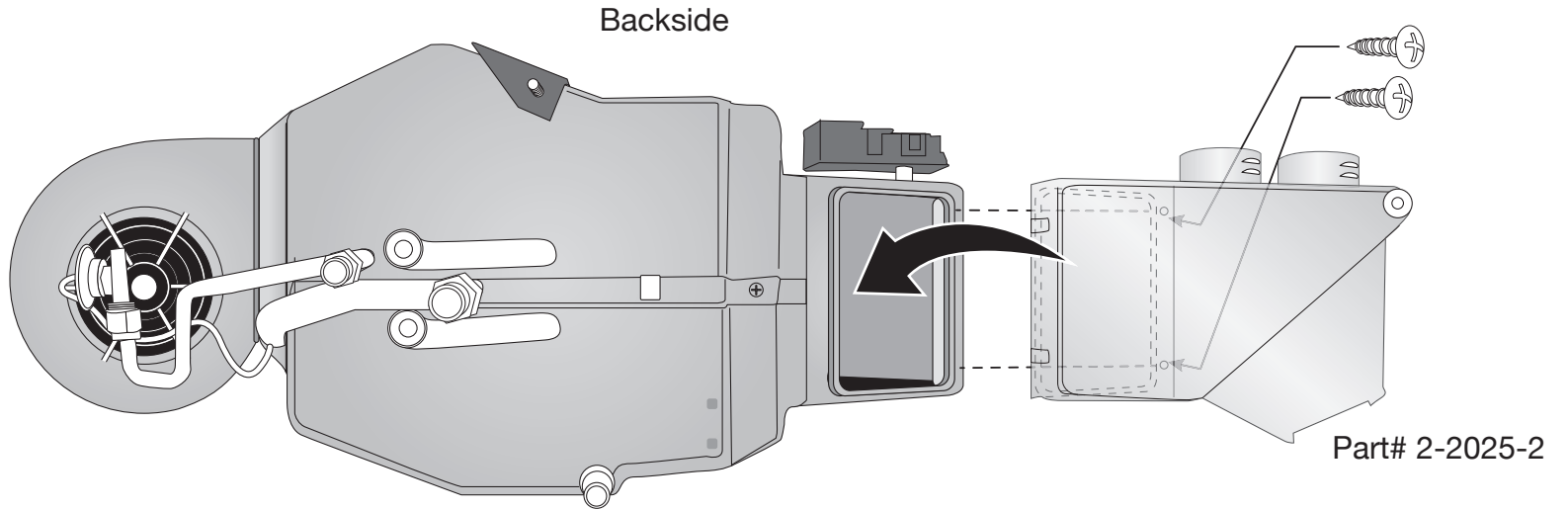

Attached to front outlet securing with pre-installed S-Clips

WIRING PREP

• Wiring Preparation Steps 1 thru 3

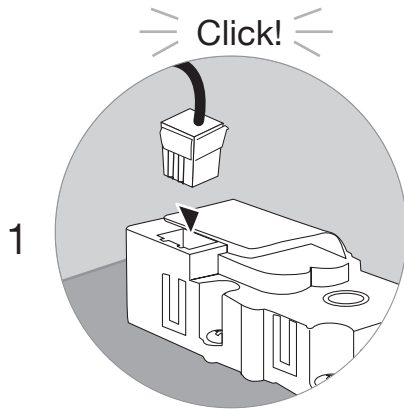

Connect Blue Harness into Defrost/Heat Servo Motor

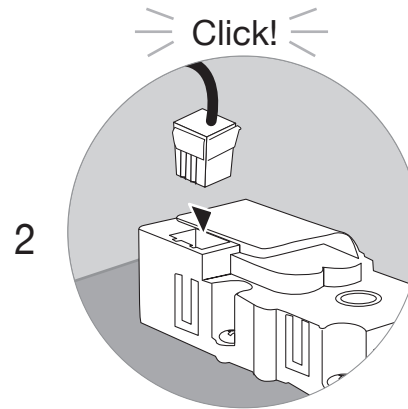

Connect Yellow Harness into Face/Floor Servo Motor

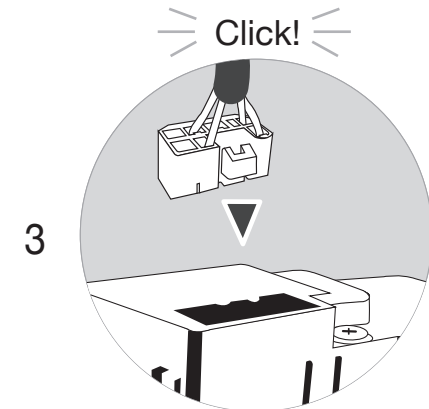

Connect Orange Harness into water valve

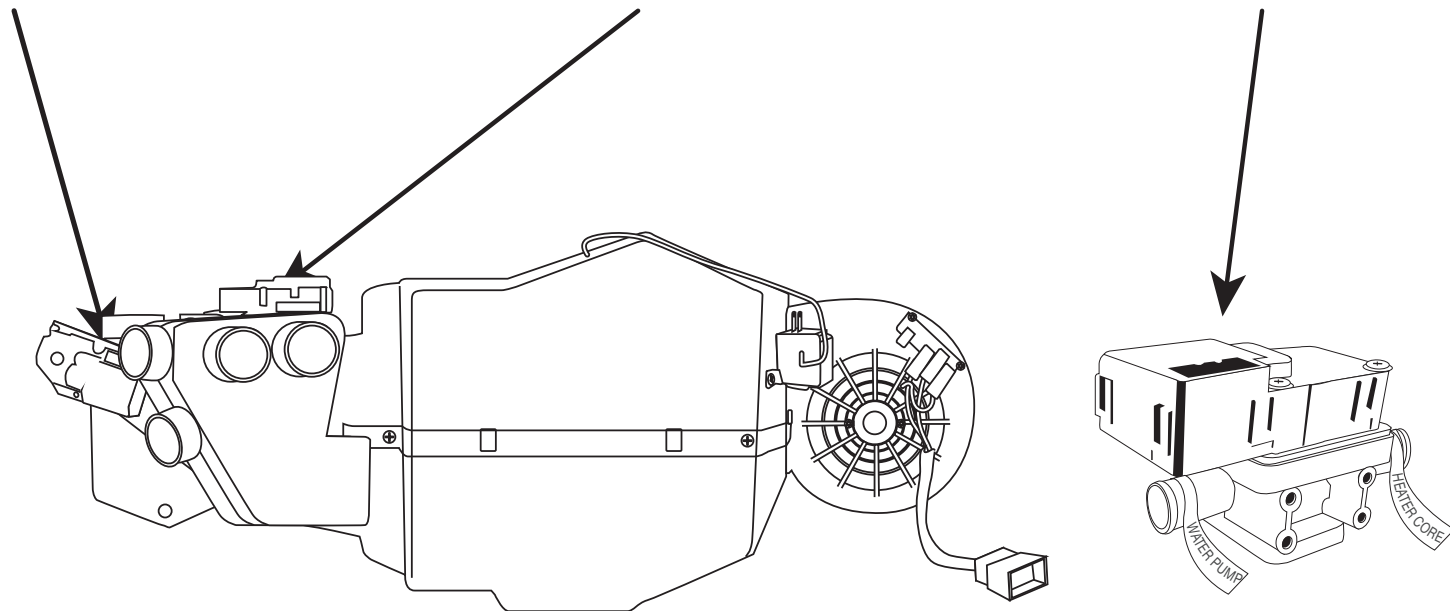

WIRING PREP

• Wiring Preparation Steps 4 thru 7

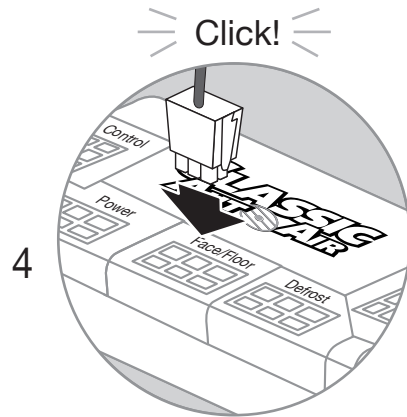

4 Connect Yellow Harness into Face/Floor Port on ECU

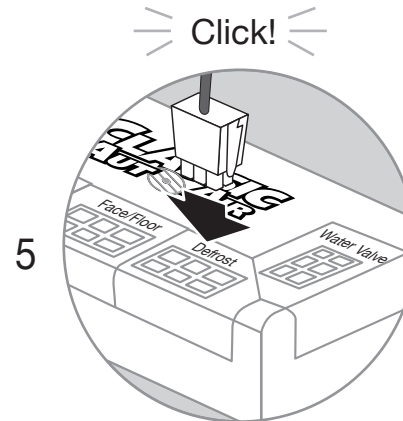

5 Connect Blue Harness into Defrost/Heat Port on ECU

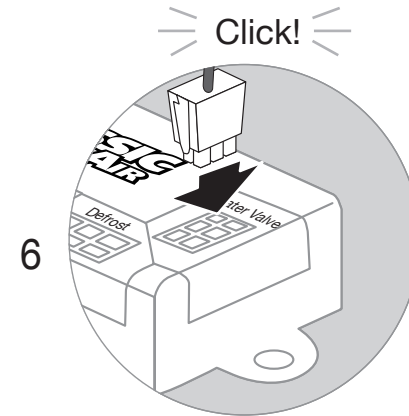

6 Connect Orange Harness into Water Valve Port on ECU

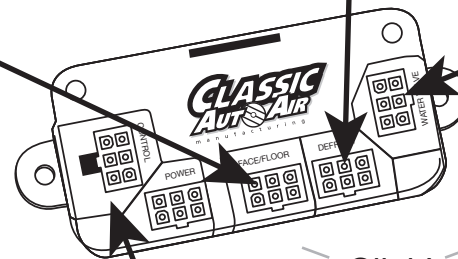

7 From your D.E.R.,
Connect Green Harness into
Control Port on ECU

Click!

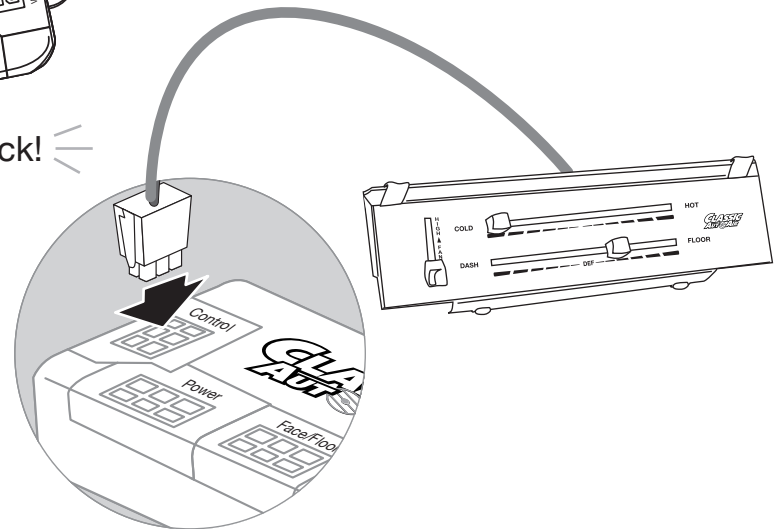

WIRING PREP

• Wiring Preparation Steps 8 through 13

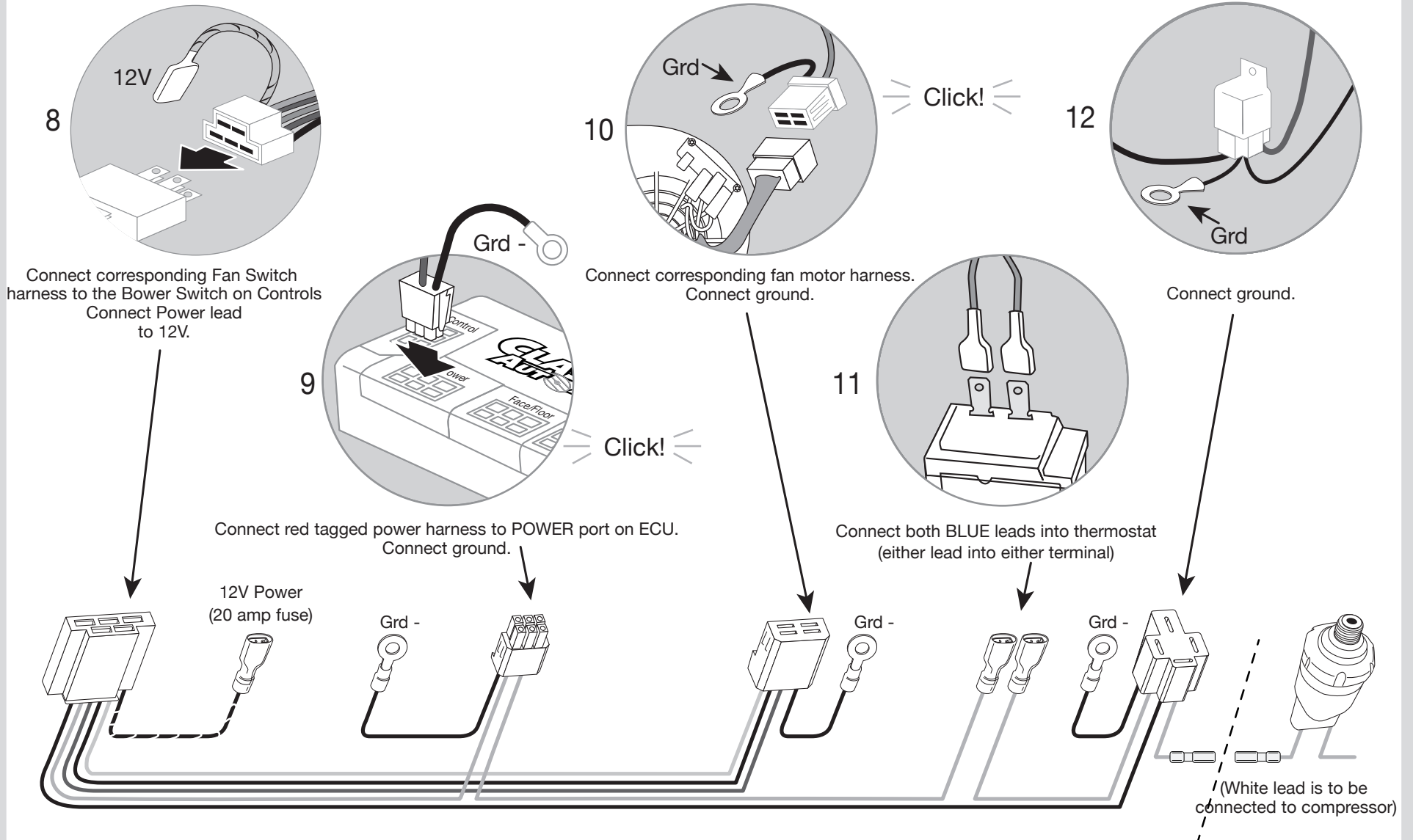

BENCH CALIBRATION & FUNCTION TESTING

• Function Test, Steps 1 thru 3

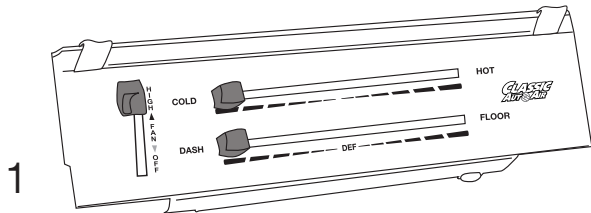

Move FAN knob to HIGH
Move MODE knob to DASH
Move TEMP knob to COLD

AIR OUT OF DASH VENTS

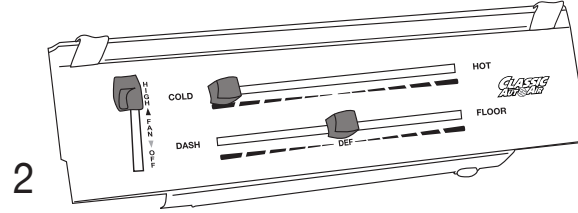
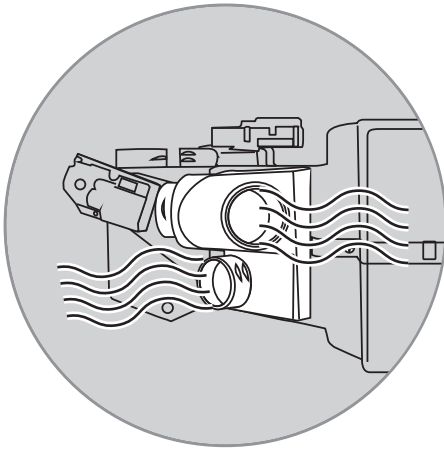

Move MODE knob to DEFROST

AIR OUT OF DEFROST VENTS

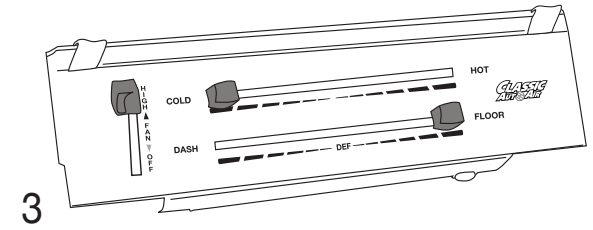
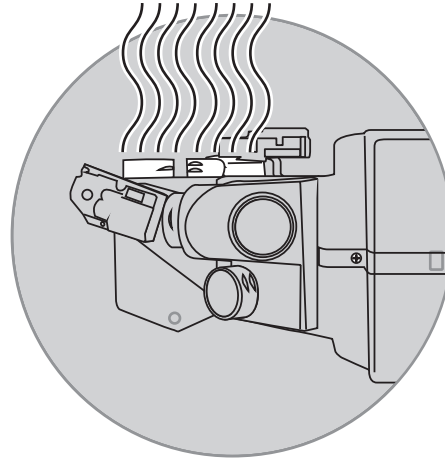

Move MODE knob to FLOOR

AIR OUT OF FLOOR VENTS

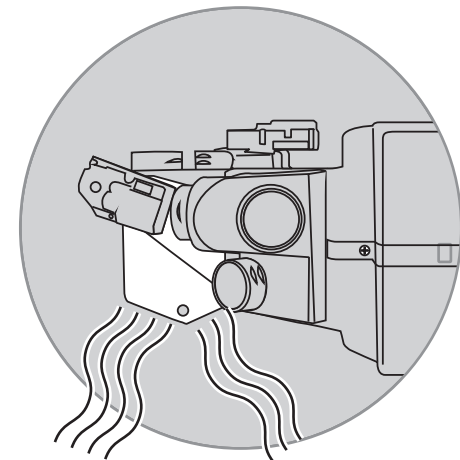

BENCH CALIBRATION & FUNCTION TESTING

- Function Test, Steps 4 and 5

4

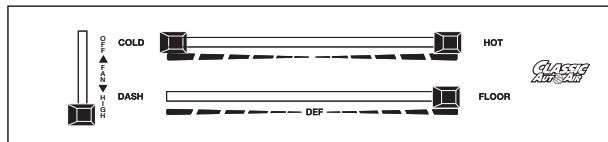

Move TEMP knob to HOT

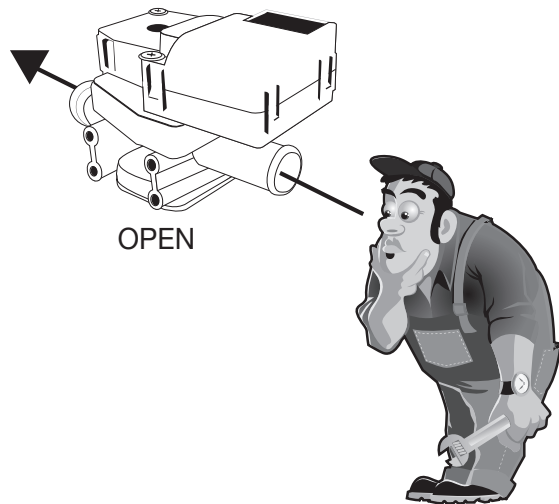

You will be able to see through water valve passage

5



Move TEMP knob to COLD

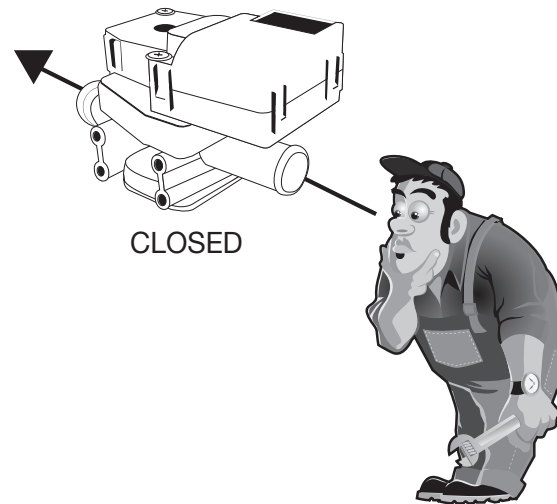

You will NOT be able to see through water valve passage

Return all wiring harnesses, water valve, and ECU to their originally bags/boxes (this keeps them organized for future installation steps).

Your controls are now fully calibrated to your unit. Please refer to the next steps in your installation manual for installing the system in your vehicle.

NOTE: IF DURING ANY OF THESE STEPS YOU DO NOT GET THE CORRECT OUTCOME, PLEASE CALL TECH SUPPORT BEFORE INSTALLING INTO VEHICLE.
1(866)435-7801

Locate the original wiring harness that supplied power to the original heater motor. GM normally used a brown wire for power. After the removal of the wire, and vacuum harness there will be a hole in the firewall. On the OEM power supply wire attach a 1/4" insulated male spade connector. Within the OEM fuse box upgrade the factory HEATER fuse with a 20 amp fuse (**VERY IMPORTANT**).

Locate the included template, piece it together from the two pages. Align the template with the upper left hand corner of the large OEM rectangular opening. Mark and drill the holes for the liquid and suction tubes.

Follow directions on the templates and drill the holes for the evaporator.
From outside of the vehicle drill the hole for the drain tube.

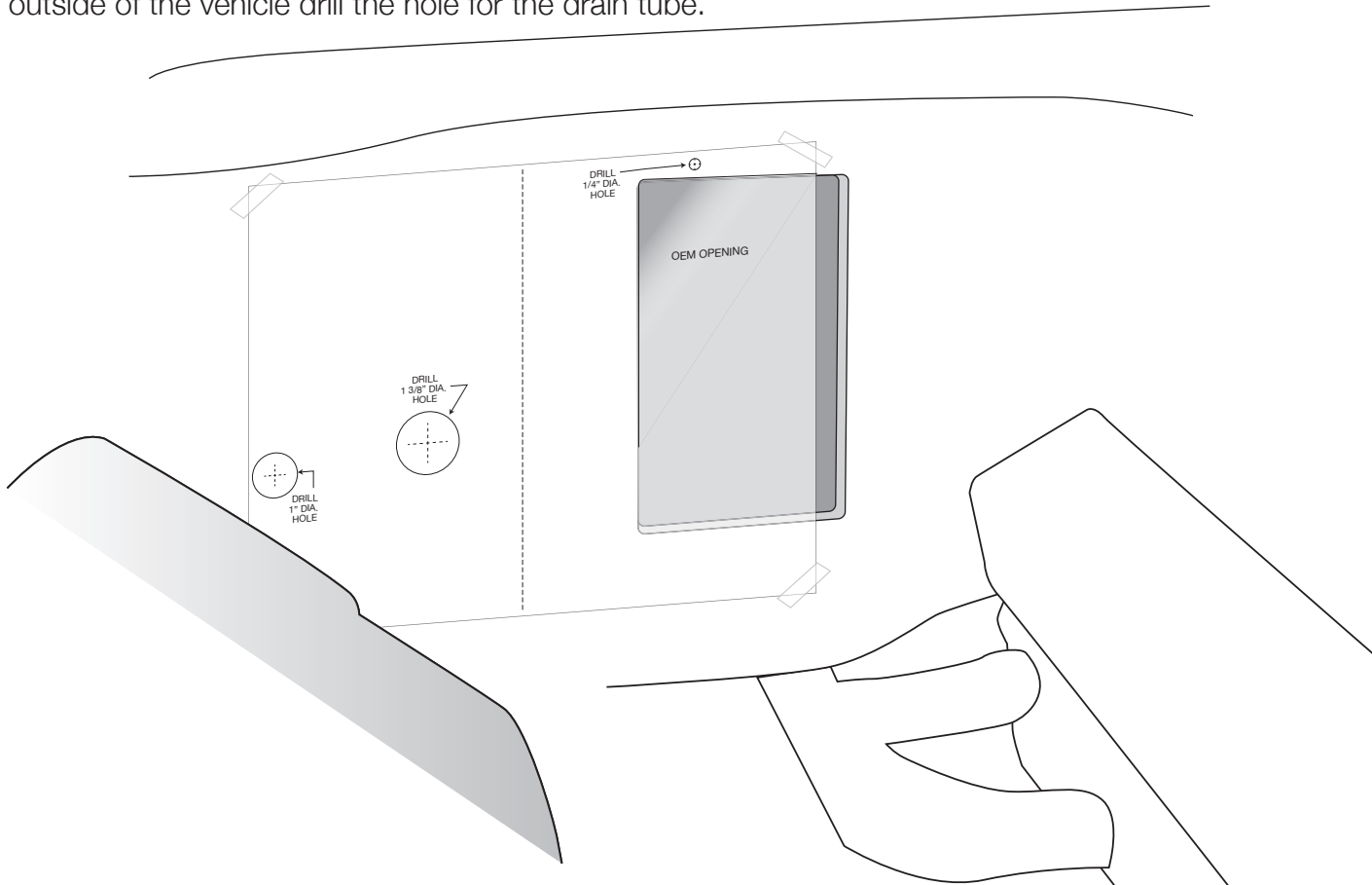

**You can now begin
installing your Classic
Air Perfect Fit Elite
System.**

NOTE: Two people are needed for this step!

Place evaporator on floor panel. Roll unit up behind the glove box opening, inserting tubes thru the large hole in firewall.

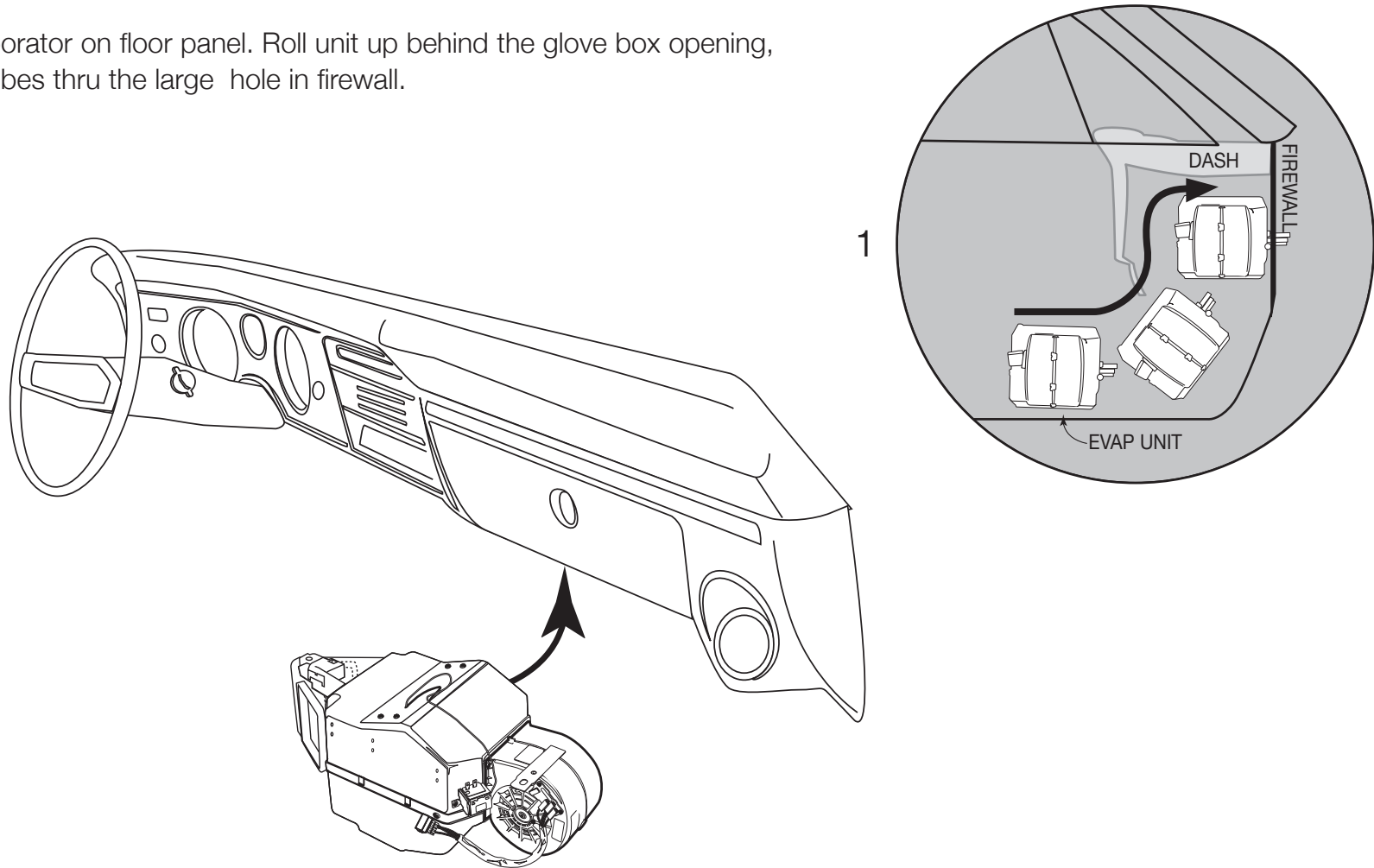
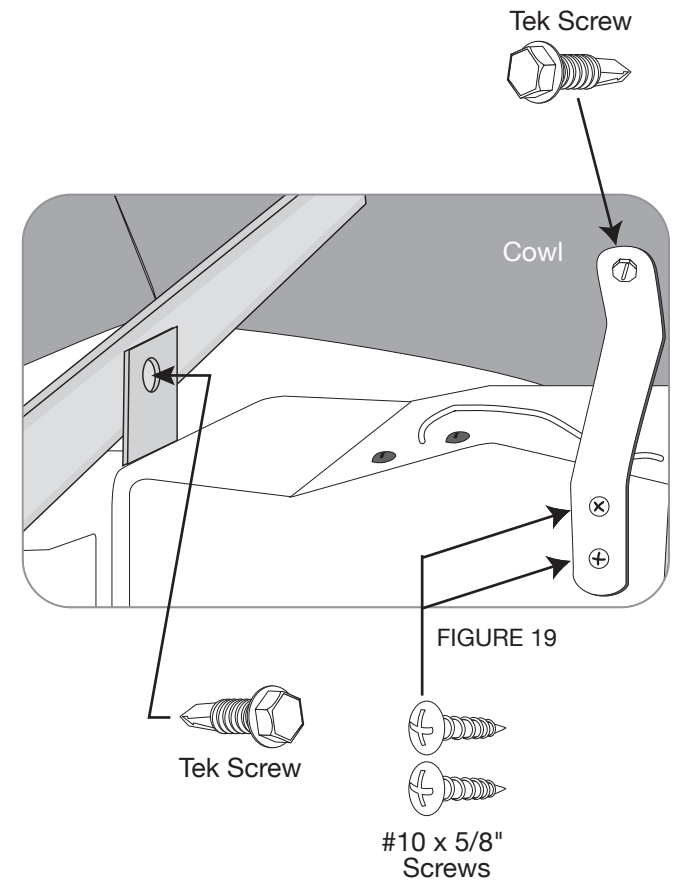
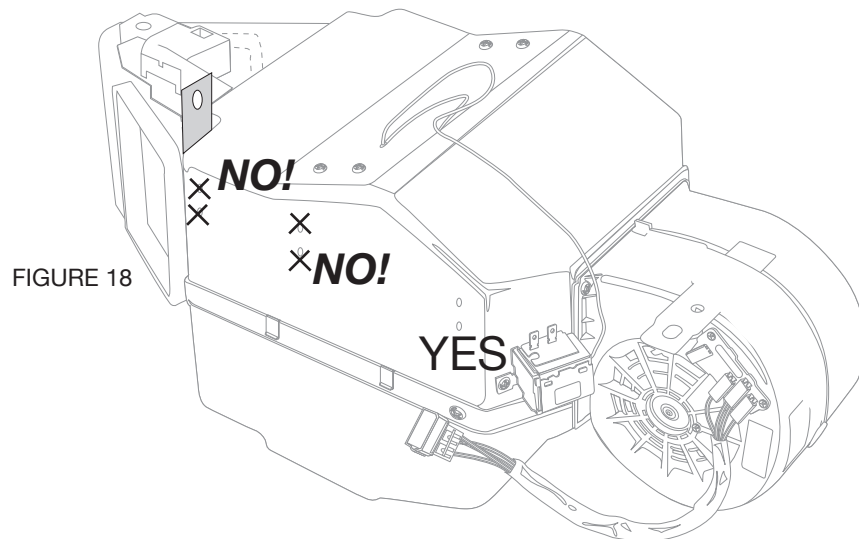
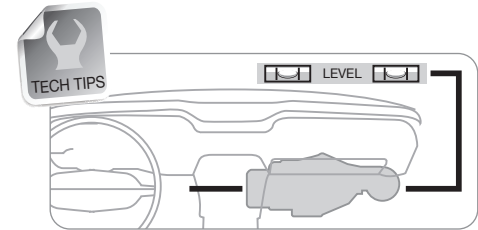

FIGURE 17

Locate the UPPER MOUNTING BRACKET and attach to evaporator unit using two #10 - 10 x 5/8" Phillips screws using a handpowered screwdriver. Level unit with lower edge of dash and attach to cowling with a #10 - 16 x 3/4" Tek Screw (see figure 18-19). **IMPORTANT NOTE: On the side of the main unit you will see several holes for mounting holes... ONLY USE THE ONES ON THE FAR RIGHT FOR THIS BRACKET!**

The other mounting point is accomplished by threading a Tek Screw thru the bracket already affixed to the evaporator and into the dash brace that is right above the evaporator unit (see figure 18-19). Make certain the unit is level with lower edge of dash and tighten screws.



Install Liquid tube onto the Expansion valve (TXV) as shown. Use #6 o-ring and (2) drops of mineral oil on the o-ring and tighten securely.

Install Suction Tube to the coil outlet on the unit as shown. Use #10 o-ring and (2) drops of mineral oil on the o-ring and tighten securely.

We've included a bulb clamp, Which you will use to attach coil to the Suction Tube as shown below.

CAUTION: YOUR SYSTEM WILL NOT FUNCTION PROPERLY IF THE SENSING COIL IS NOT CLAMPED IN THE CORRECT POSITION. SEE THE DIAGRAM BELOW.

Once the sensing coil is installed, wrap suction tube and coil with refrigerant tape. Be sure that all of the exposed metal is covered.

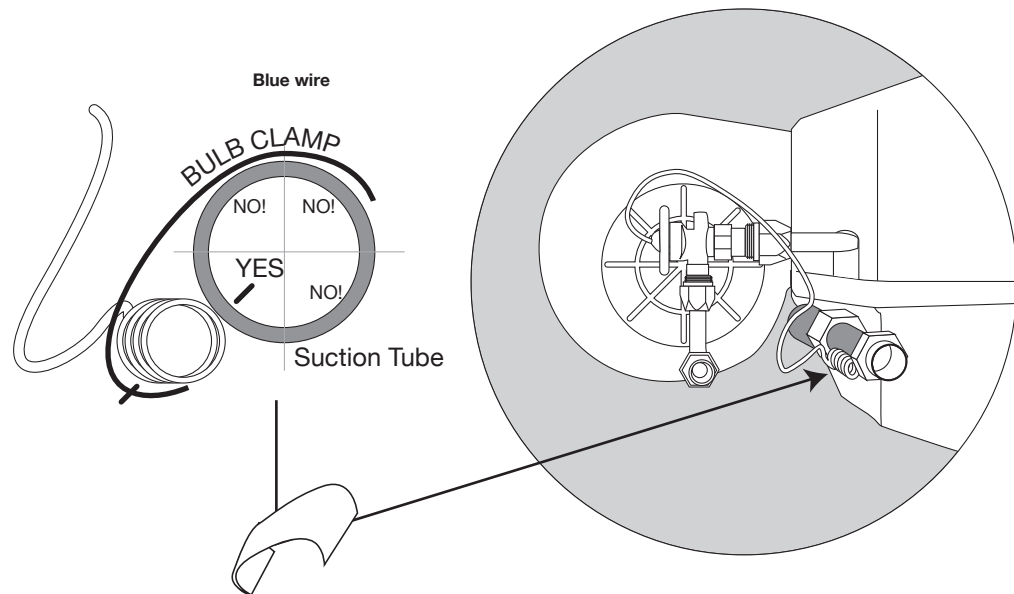
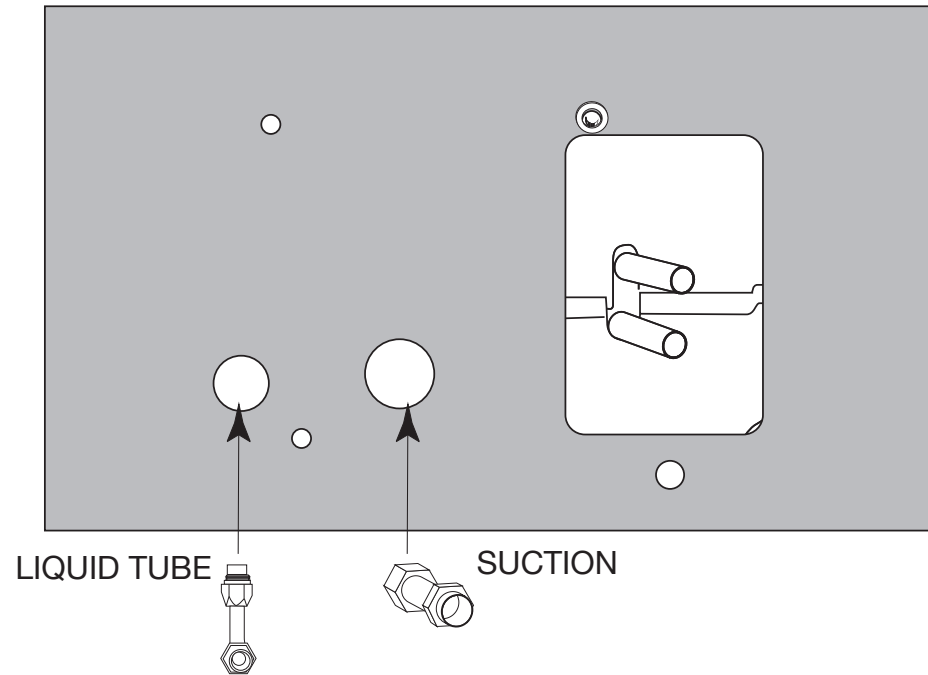

Reminder...
Use two wrenches to tighten o-ring fittings

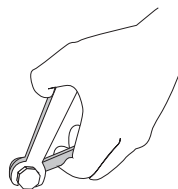

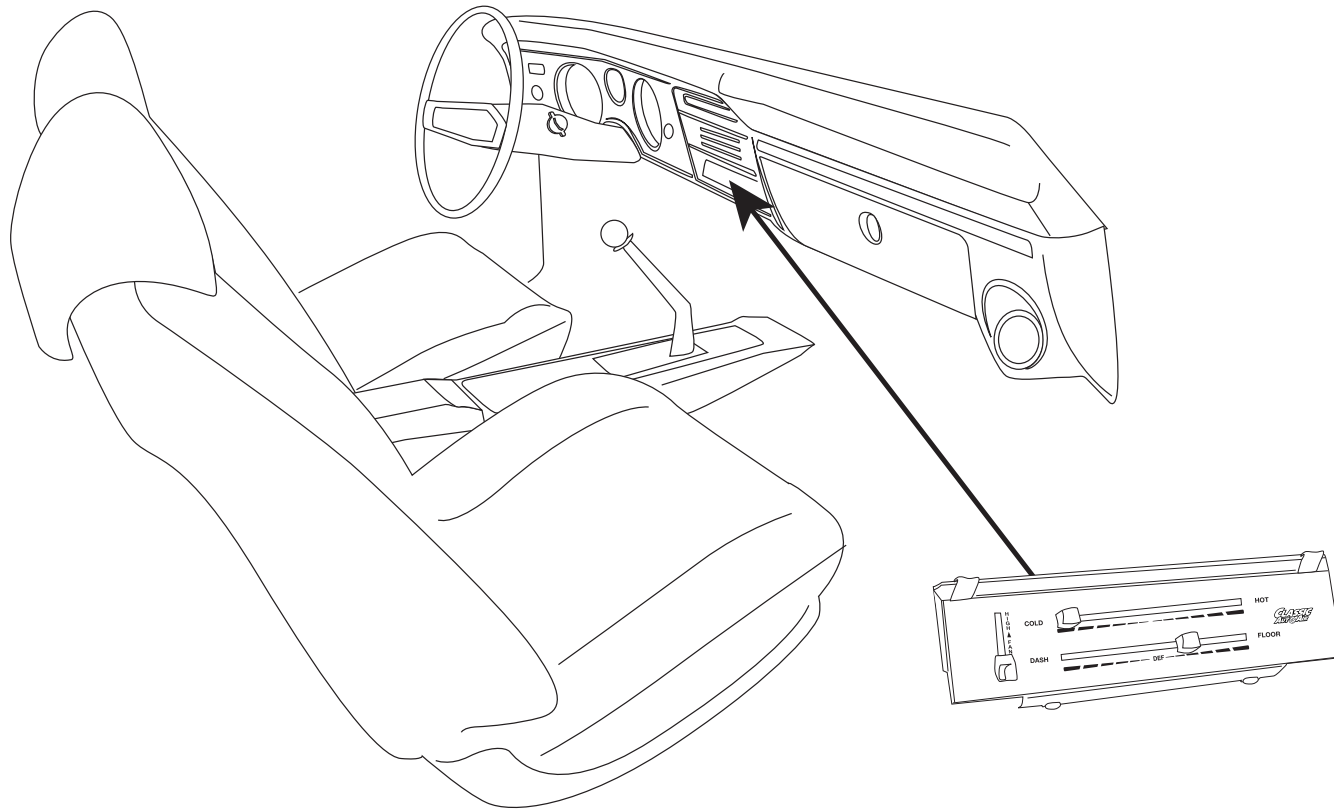



THESE ARE THE PARTS YOU WILL FIND IN BAG KIT C

You will use all of these parts and hardware during the next series of installation steps.

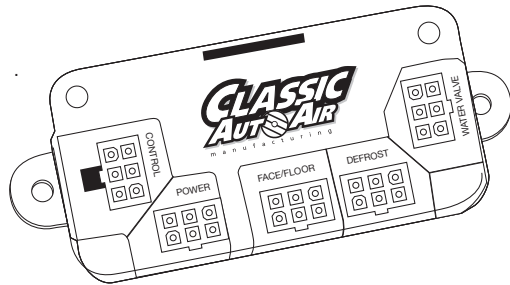

*ECU and Calibration Key
DO NOT USE CALIBRATION KEY
WITHOUT TECH SUPPORT*

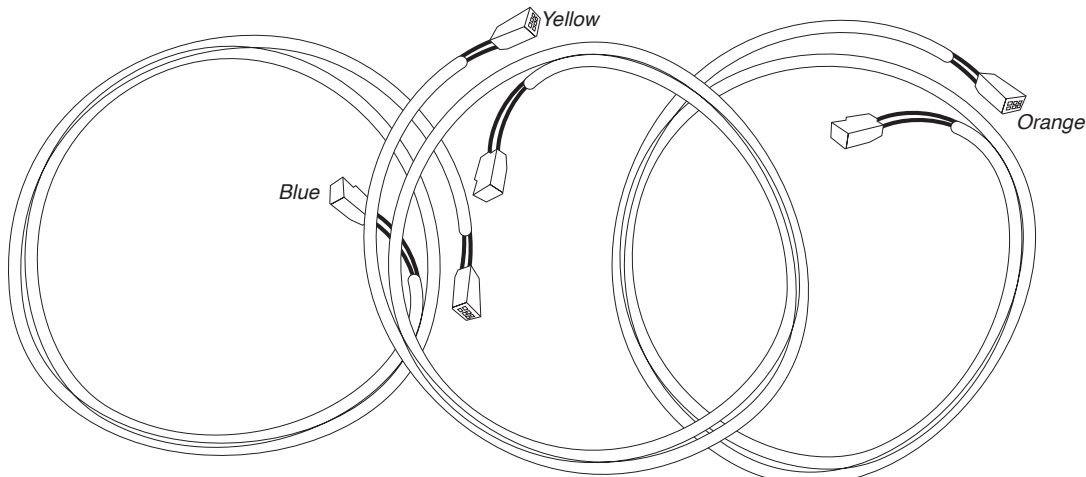

EZ Wire Harness System

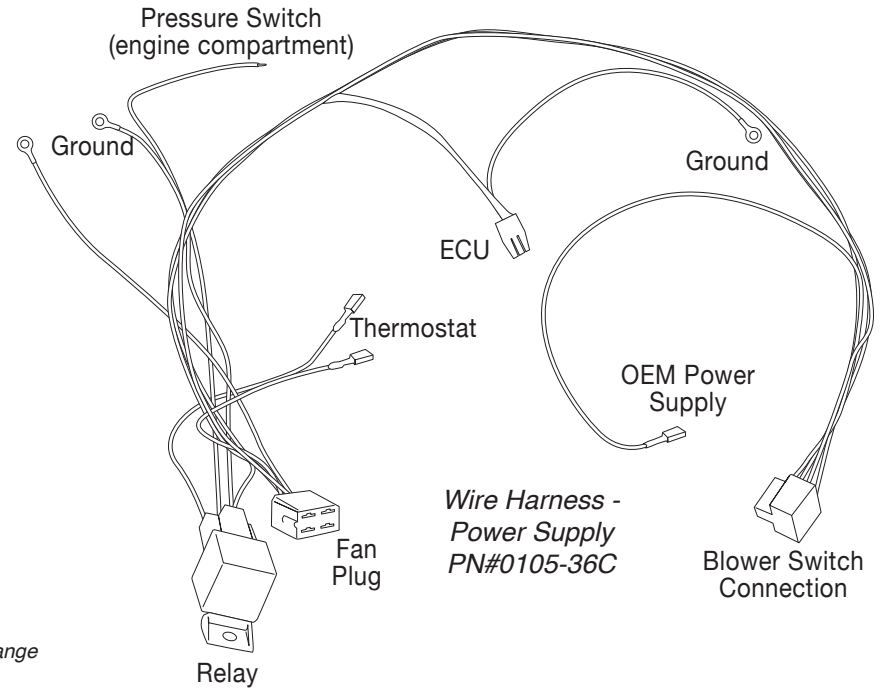

*Wire Harness -
Power Supply
PN#0105-36C*

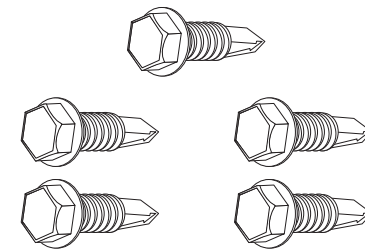

Five #10 - 16 x 3/4" Tek Screws

Illustrations NOT shown actual size

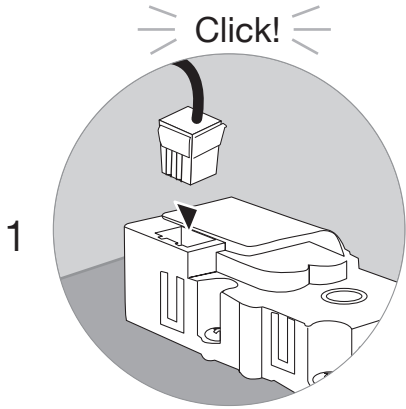

Connect Blue Harness into Defrost/Heat Servo Motor

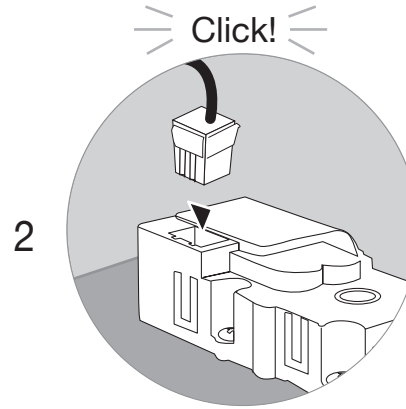

Connect Yellow Harness into Face/Floor Servo Motor

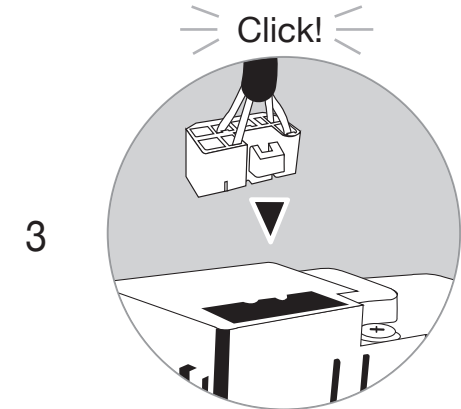

Connect Orange Harness into water valve

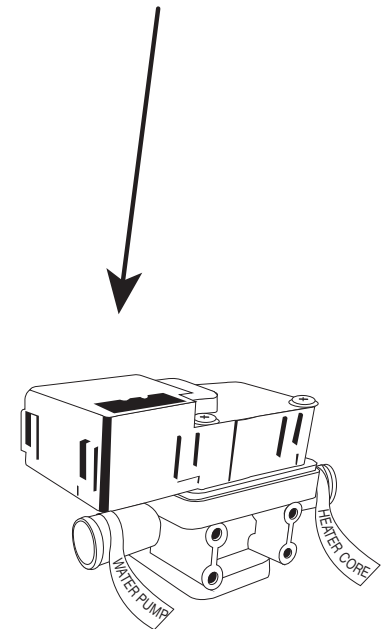
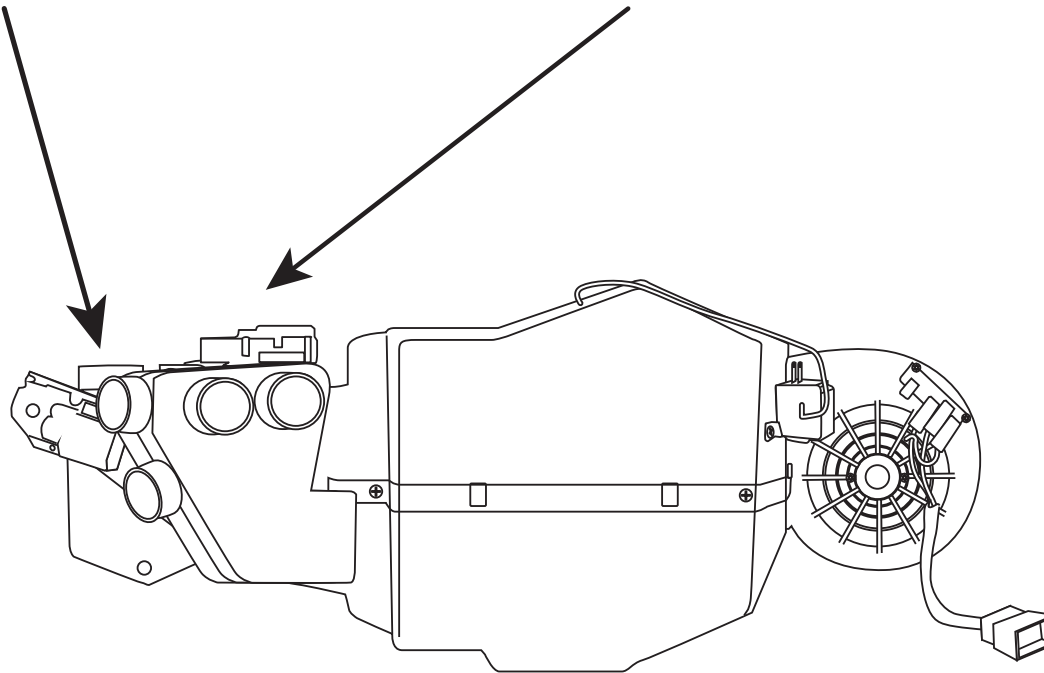

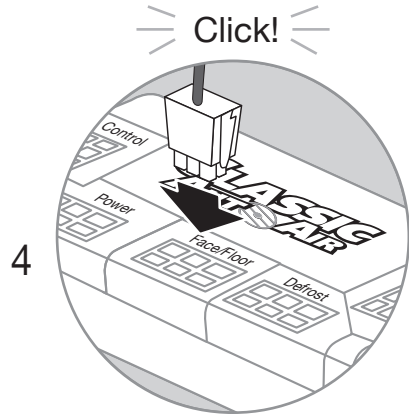

4 Plug Yellow Harness into Face/Floor Port on ECU

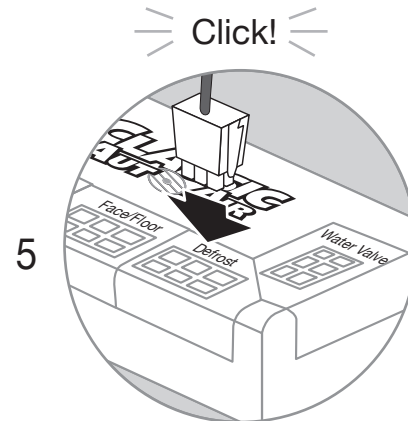

5 Plug Blue Harness into Defrost/Heat Port on ECU

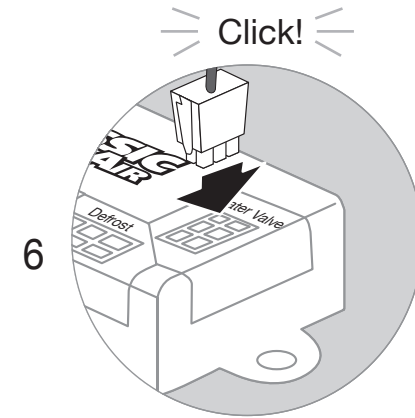

6 Plug Orange Harness into Water Valve Port on ECU

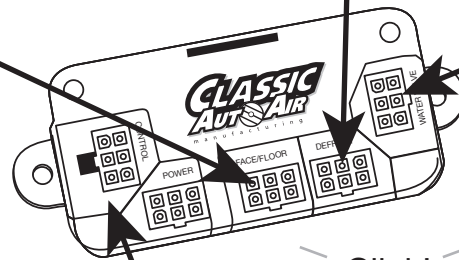

7 From your controls connect Green Harness into Control Port on ECU

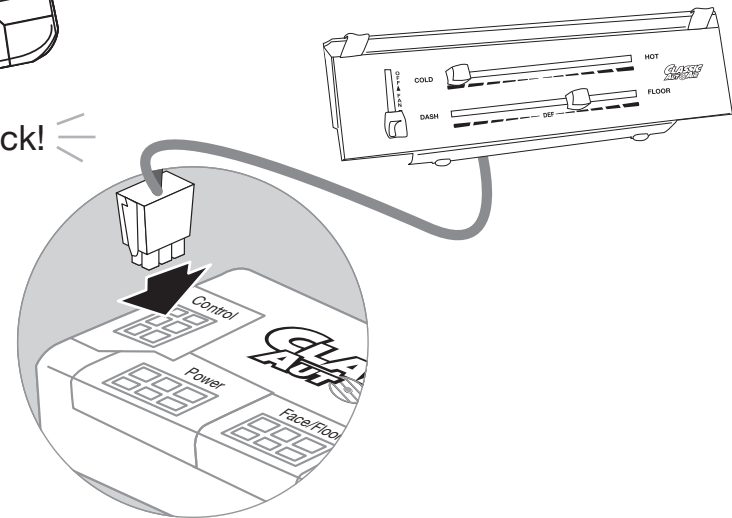

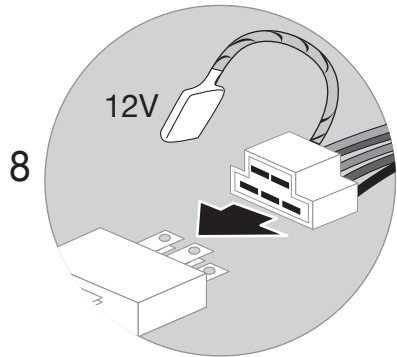

8

12V

Connect corresponding Fan Switch harness to the Bower Switch on Controls
Connect Power lead to 12V.

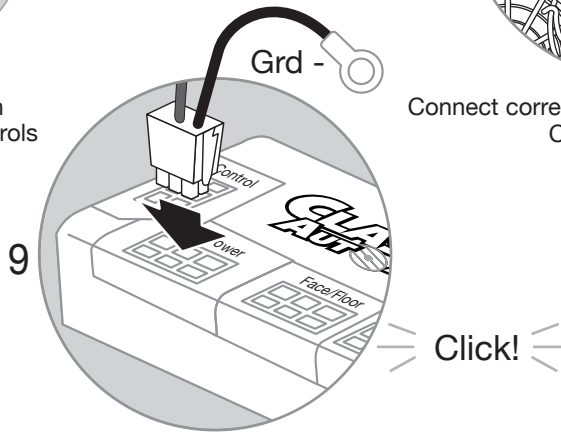

9

Grd -

Click!

Connect red tagged power harness to POWER port on ECU.
Connect ground.

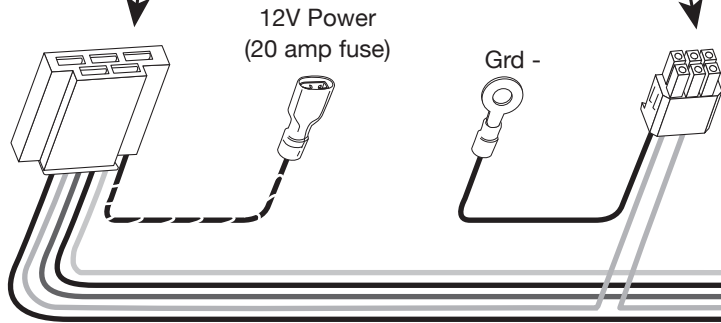

12V Power
(20 amp fuse)

Grd -

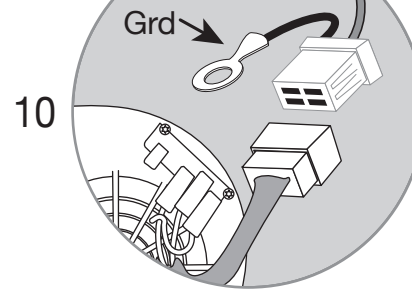

10

Grd

Connect corresponding fan motor harness.
Connect ground.

Click!

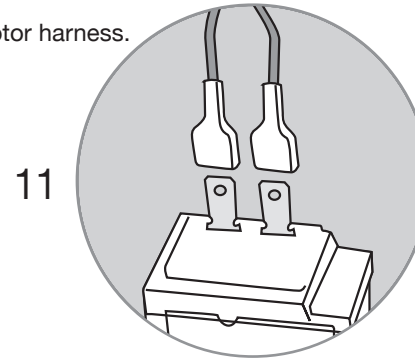

11

Connect both BLUE leads into thermostat
(either lead into either terminal)

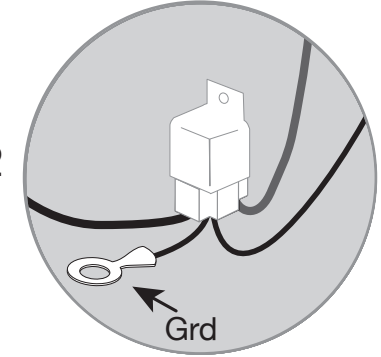

12

Grd

Connect ground.

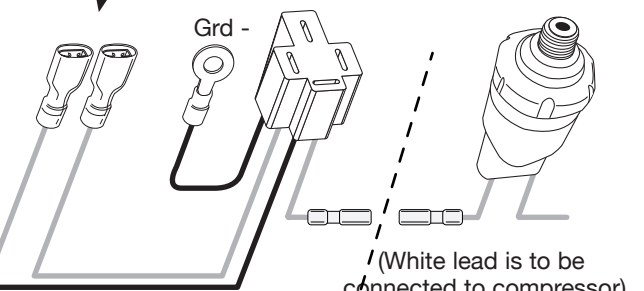

(White lead is to be connected to compressor)

THESE ARE THE PARTS YOU WILL FIND IN BAG KIT D

You will use all of these parts and hardware during the next series of installation steps.

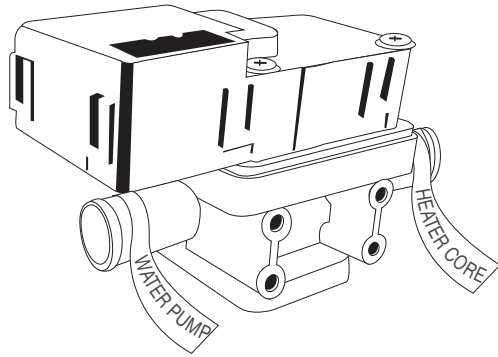

Electronic Water Control Valve
PN#16-1081-2



Clear Plastic Drain Tube

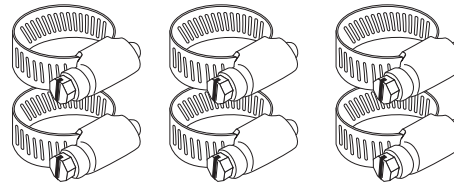

Six Worm Gear Clamps

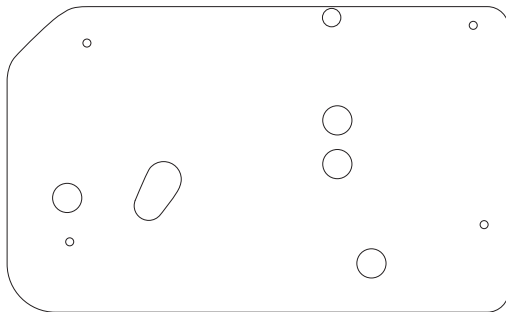

Firewall Block Off
PN#10-2055FA-1

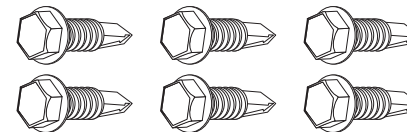

Six #10 - 16 x 3/4" Tek Screws

Illustrations NOT shown actual size

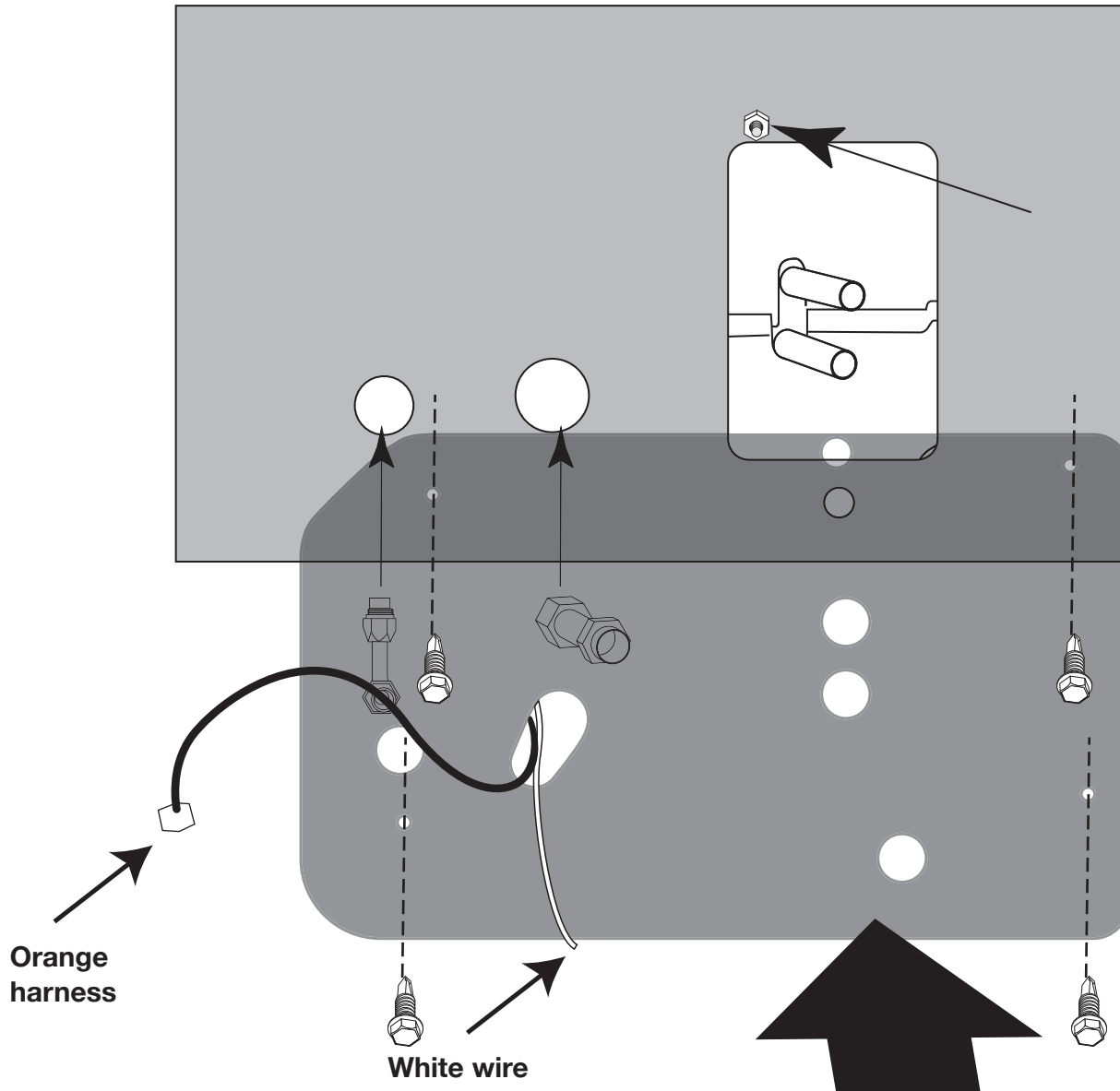

In **Bag Kit D** you'll find the firewall block off. Install this over the hose connections coming through the firewall within the engine compartment. Attach with six #10 - 16 x 3/4" Tek screws.

TIP: Route ORANGE cable through the block off plate (it will be plugged into the electronic water valve).

The loose white wire from main power harness can be fed through the same hole (as shown below).

Match drill drain tube hole.

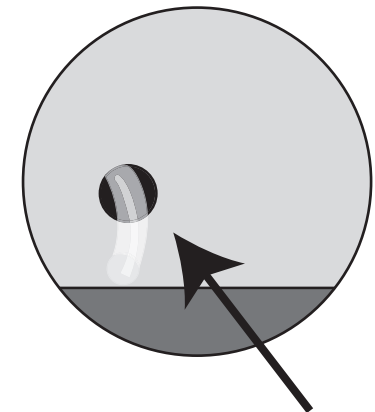

Feed drain tube thru the hole.

IMPORTANT NOTICE: PROPER INSTALLATION OF WATER VALVE

Your water valve MUST be installed per these instructions!... (If not, your system will not work properly.

The **lower** heater tube connection on firewall will be routed to the water connection on intake manifold using 5/8" dia. heater hose with the supplied worm gear clamp.

The **upper** heater tube connection on the firewall will be routed to the water valve connection labeled **heater core**, using a 6" piece of 5/8" heater hose attached with supplied worm gear clamp.

Connect the remaining outlet on water valve labeled **water pump** to the water pump using 5/8" dia. heater hose with the supplied worm gear clamp.

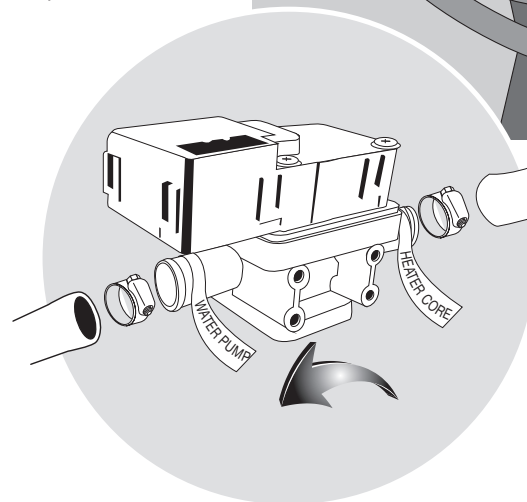
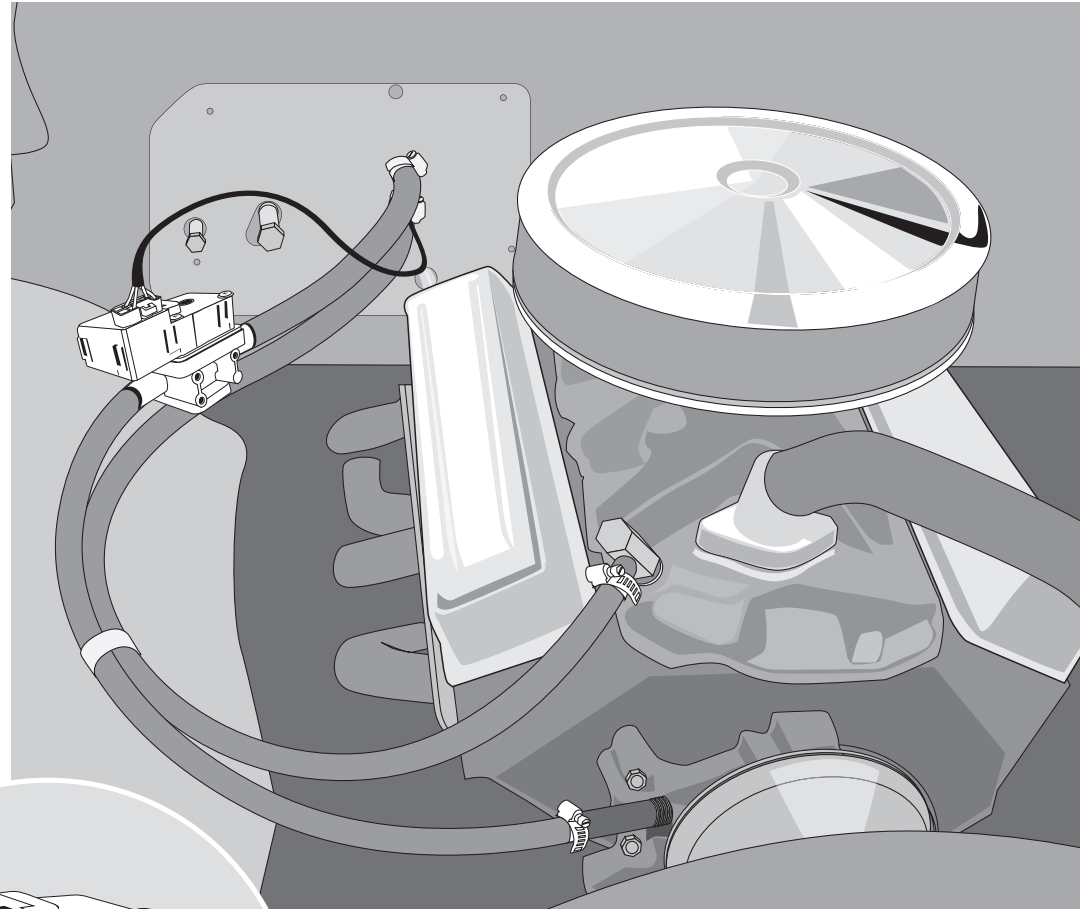

**FOLLOW THESE
TAGS... CHECK IT
TWICE BEFORE
PROCEEDING!**

THESE ARE THE PARTS YOU WILL FIND IN BAG KITS E, F, and G

You will use all of these parts and hardware during the next series of installation steps.

Bag E

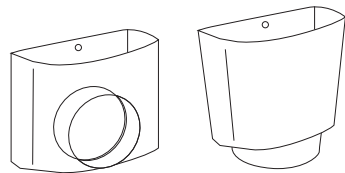

Two Defrost Adaptors
PN#034-15 and 034-14



Four #10 - 10 x 5/8" Phillips Screws

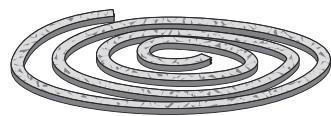

Foam Tape

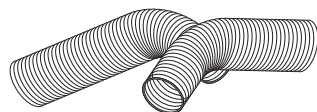

Two Duct Hoses, 2" I.D.



Four Zip-Ties

Bag F

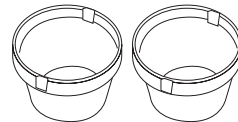

Louver Adaptors PN#2-2093-1

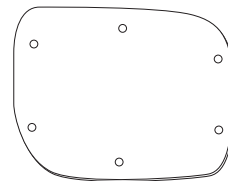

Recirculation
Door Block Off
PN#10-1505-2

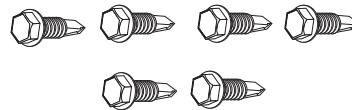

Six #10 - 16 x 3/4" Tek Screws

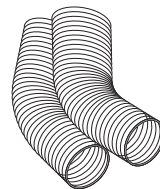

Two Duct Hoses, 2" I.D.



Four Zip-Ties

Bag G

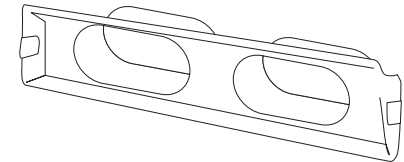

Center Dash Vent Adaptor
PN# 2-1505-1

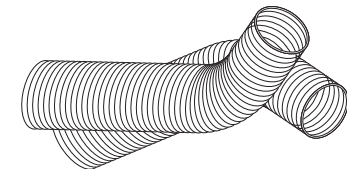

Two Duct Hoses, 2" I.D.



Four Zip-Ties

Locate and route the duct hoses from the defrost/heat duct assembly upward toward defrost vents. Attach the flex hose to the defrost defuser using zip-ties. The other end of the duct hose is installed over the defrost/heat duct assembly outlets on main unit (see figure 24).

The defrost duct hoses can now be routed upward and attached to the adapters using the included zip-ties.

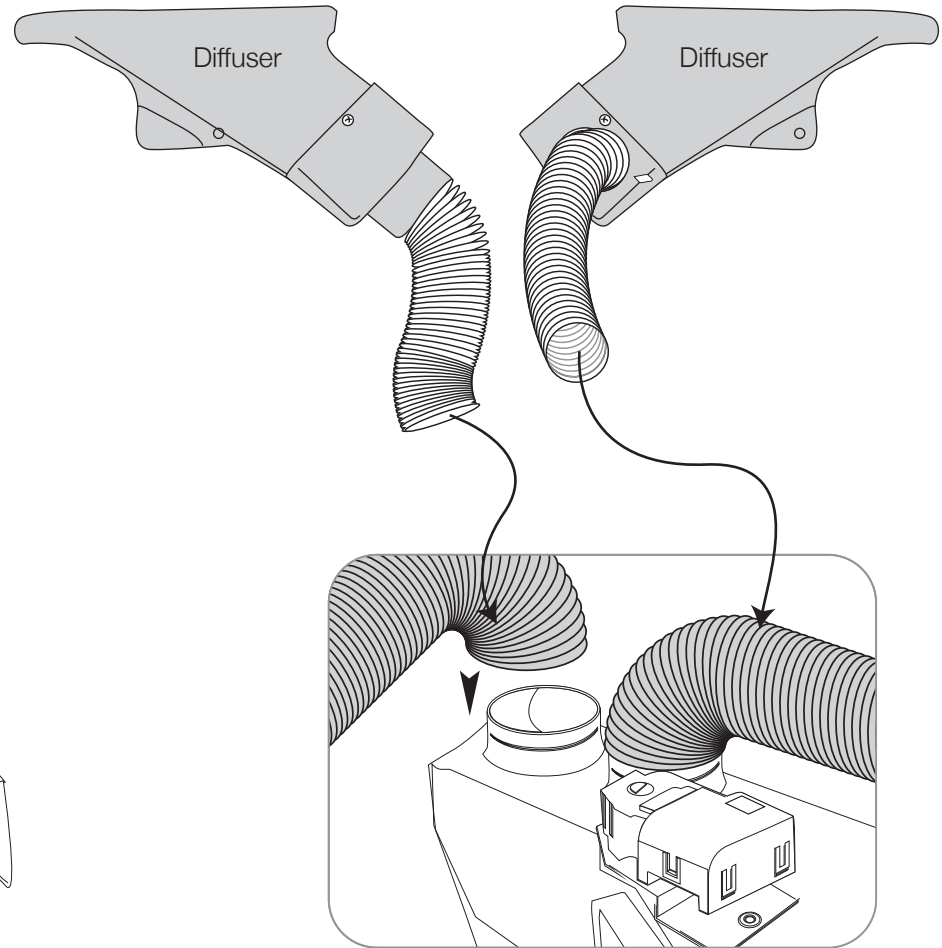
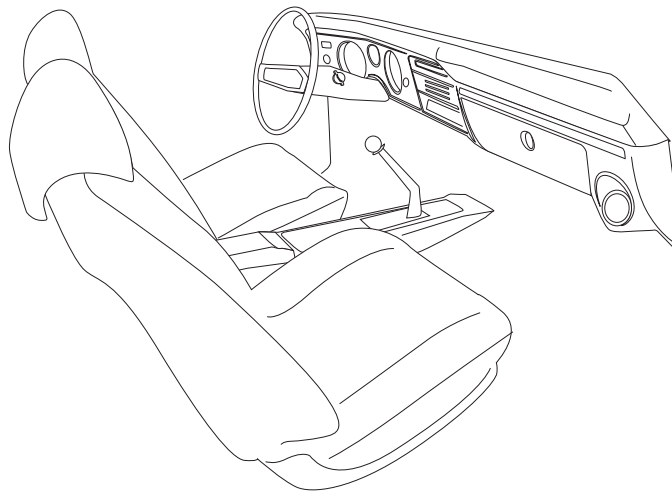

FIGURE 24



The smoother the route of the flex hoses the better the airflow.



Bag Kit F:

Attach louver adaptors to the back side of the OEM louvers, both sides.
S-Clips will hold them in place.

Route supplied flex hoses as shown below. Take your time and route them so they don't become kinked or torn.

Figure 20

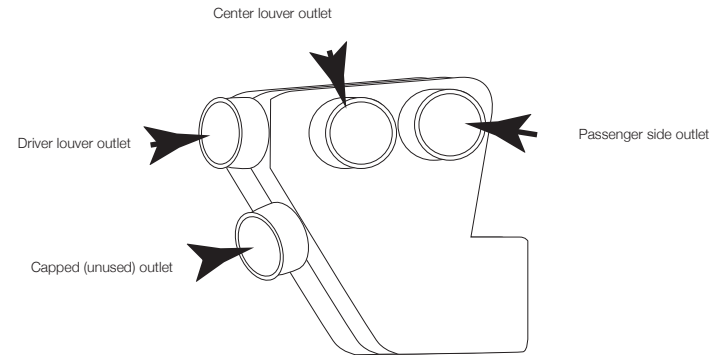
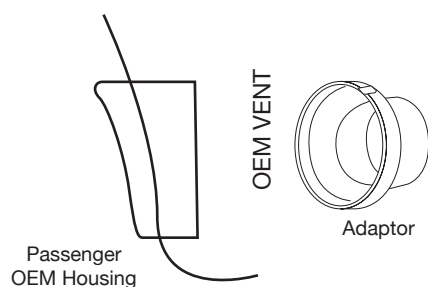
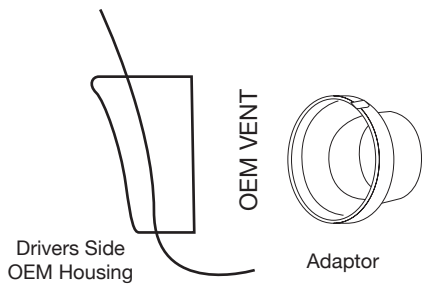
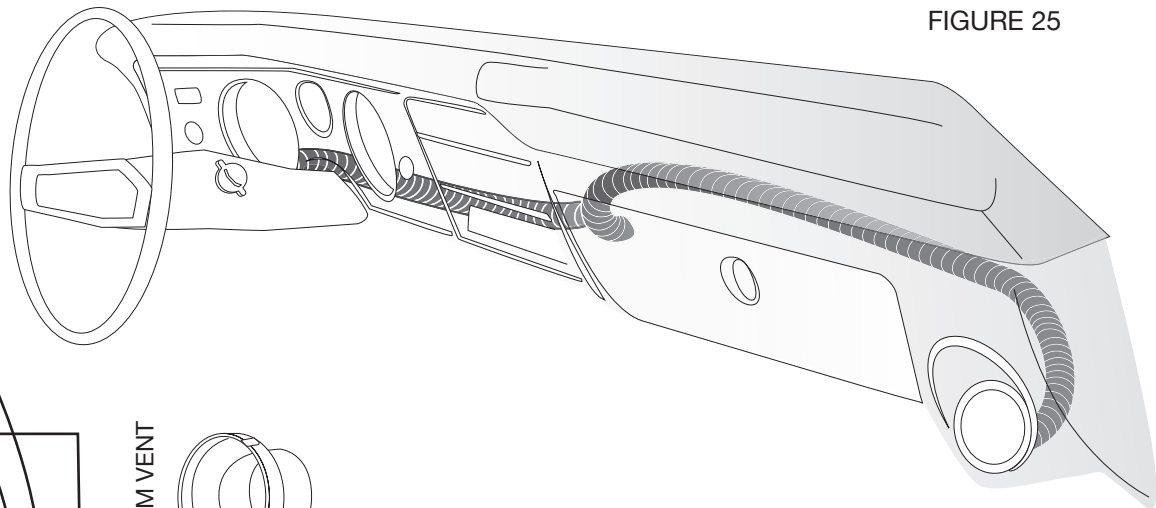

FIGURE 25



The smoother the route of the flex hoses the better the airflow.



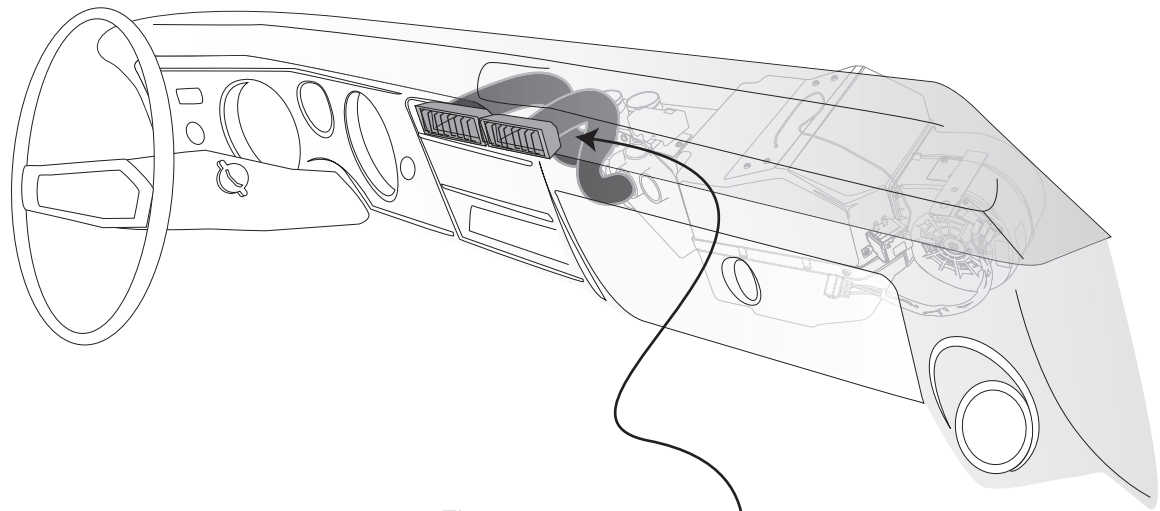

Figure 26

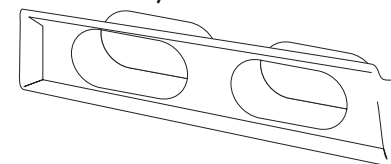
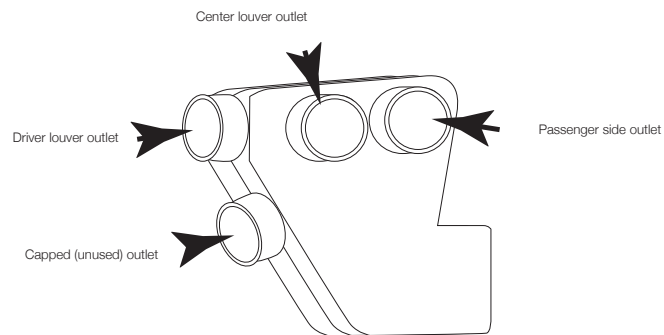
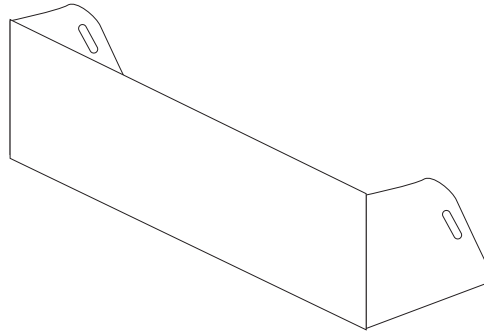

Figure 20



The smoother the route of the flex hoses the better the airflow.



We've included a replacement glovebox that you can install at this point. We've included screws, and you'll attach the new glovebox to the OEM glovebox door.

This completes the interior portion of the **PERFECT FIT-ELITE** installation process. This is a good time to make a final check that all the controls still move freely and that nothing is loose or hanging down.

The interior of your car should look pretty much the same as before you started (or better). Plus you probably got to know the underside of your dash a lot better and might even have repaired or upgraded components that needed attention.

If you have any questions before you move on the final phase of this installation, call us.

Good Job... Let's move on to the major components within the engine compartment....

THESE ARE THE PARTS YOU WILL NEED FOR THE ENGINE COMPARTMENT INSTALLATION ON A 1969 CHEVELLE

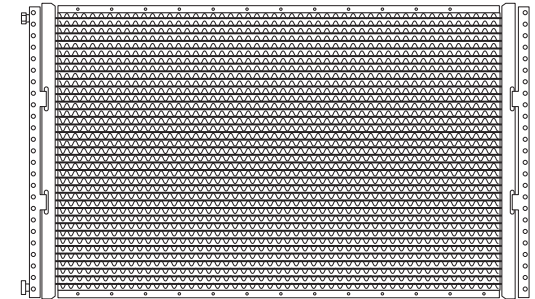
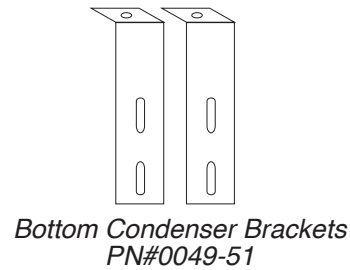
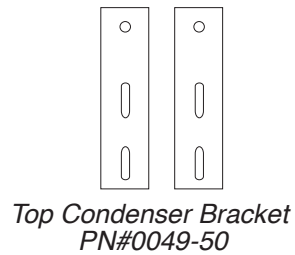
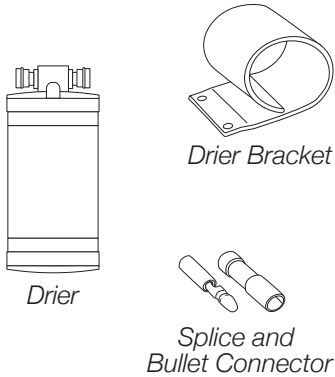

Condenser
PN#11-1041

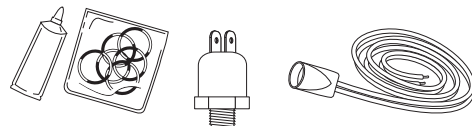
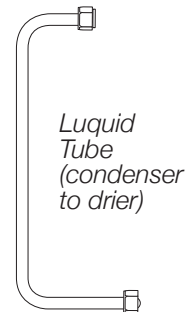
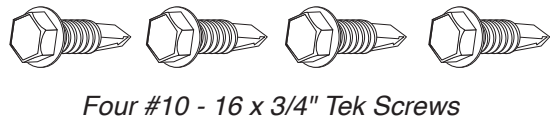

Pressure Switch and harness,
Bag of O-rings and Mineral Oil Tube

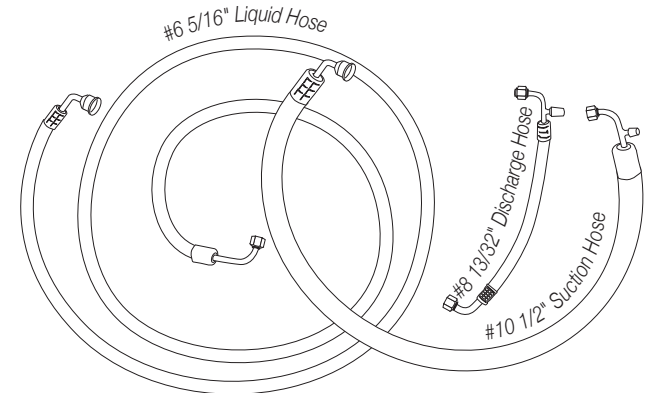

Three Refrigerant Hoses

DRIER AND CONDENSER PREPARATION. You can perform most of the following steps on a clean flat surface like a workbench. Lay the condenser down so that both hose connections are on the left side (the larger connection will be on top). The drier is conveniently mounted on the left hand side of the condenser. First insert the drier into the drier mounting bracket. Attach the drier liquid tube to the drier and also to the connection on the condenser (tighten connections at either end using supplied o-rings on both ends and a few drops of mineral oil to each o-ring). With these two combined it will be easy to find the correct place to attach the drier bracket to the condenser with the included #10-20 x 1/4" screws (attach drier and bracket from the front of the condenser).

BRACKETS: Install the upper condenser brackets using four #10 - 20 x 3/8" screws as shown in figure 28. Next, attach the lower brackets in the positions shown in figure 29.

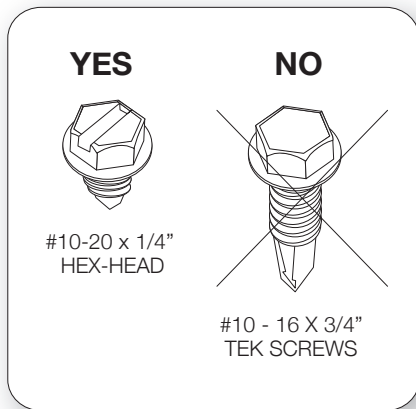
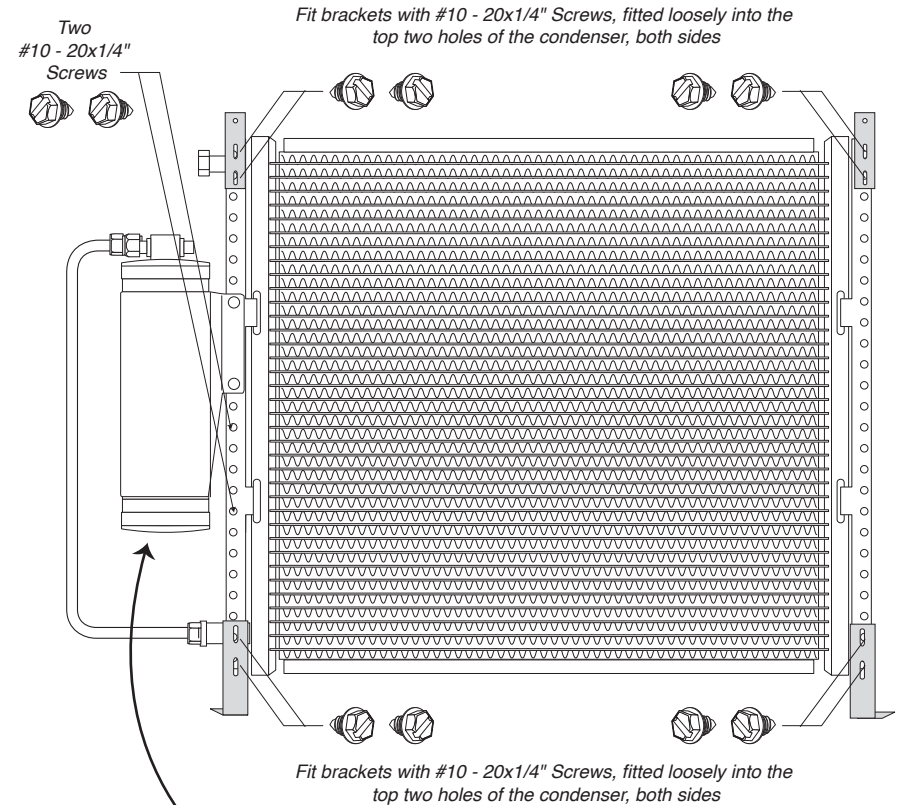

You can easily find the correct position for mounting the drier to the condenser by using the drier liquid tube as a gauge.

For the next series of steps you may need to remove the battery. Carefully place the entire condenser assembly through the radiator bulkhead and center in opening. Attach condenser to front side of radiator core support using four #10- 16 X 3/4" Tek screws.

Locate and drill a 1-1/2" hole through the support directly inline with the upper refrigerant fitting on the condenser. The #8 hose will go this hole, you can use the hose as a guide before you drill also. **THE LOCATION OF THIS HOLE IS IMPORTANT, SO DOUBLE CHECK BEFORE DRILLING.** After drilling, place an included grommet into holes (see figure 30).

Next, drill another 1-1/2" hole approximately 2" below the first hole. Install grommet into this hole also.

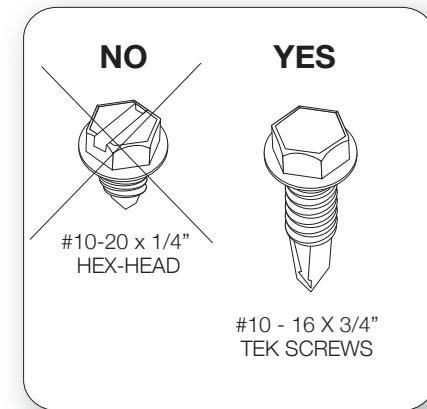
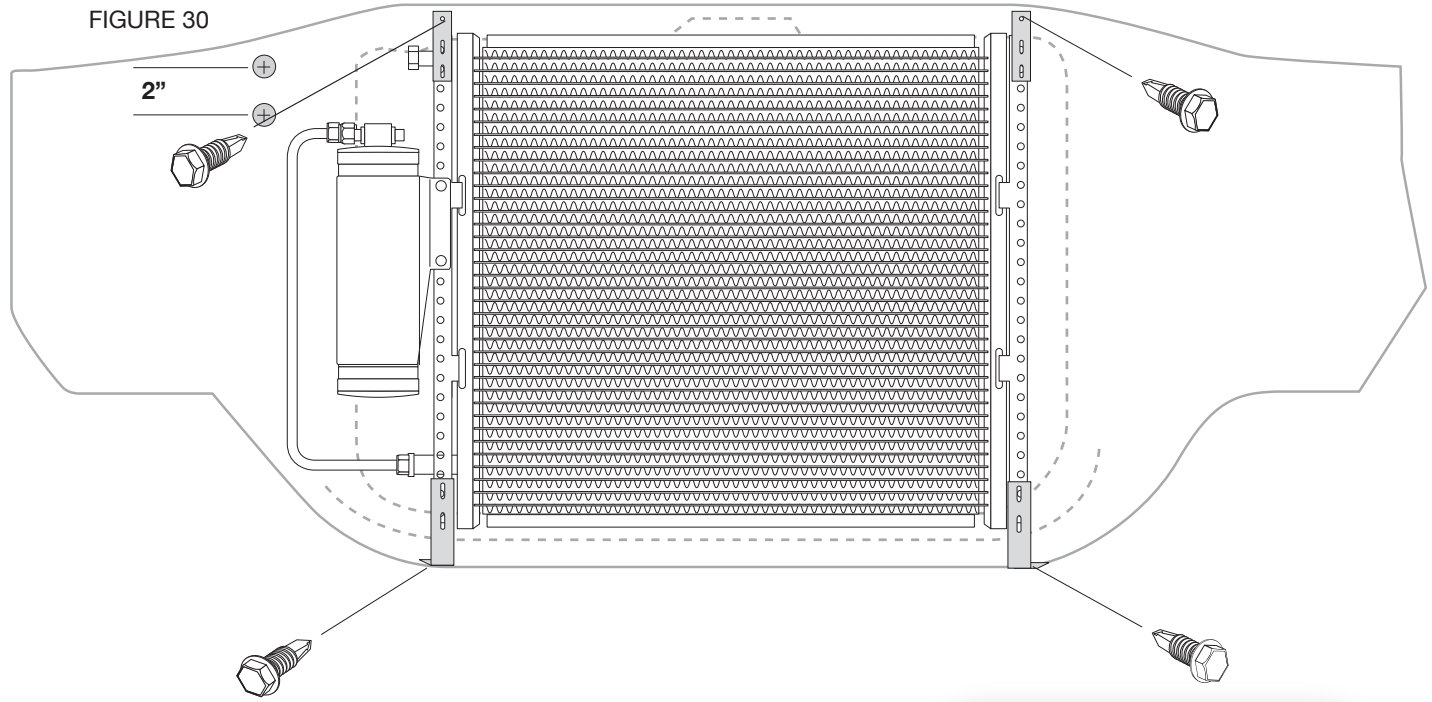

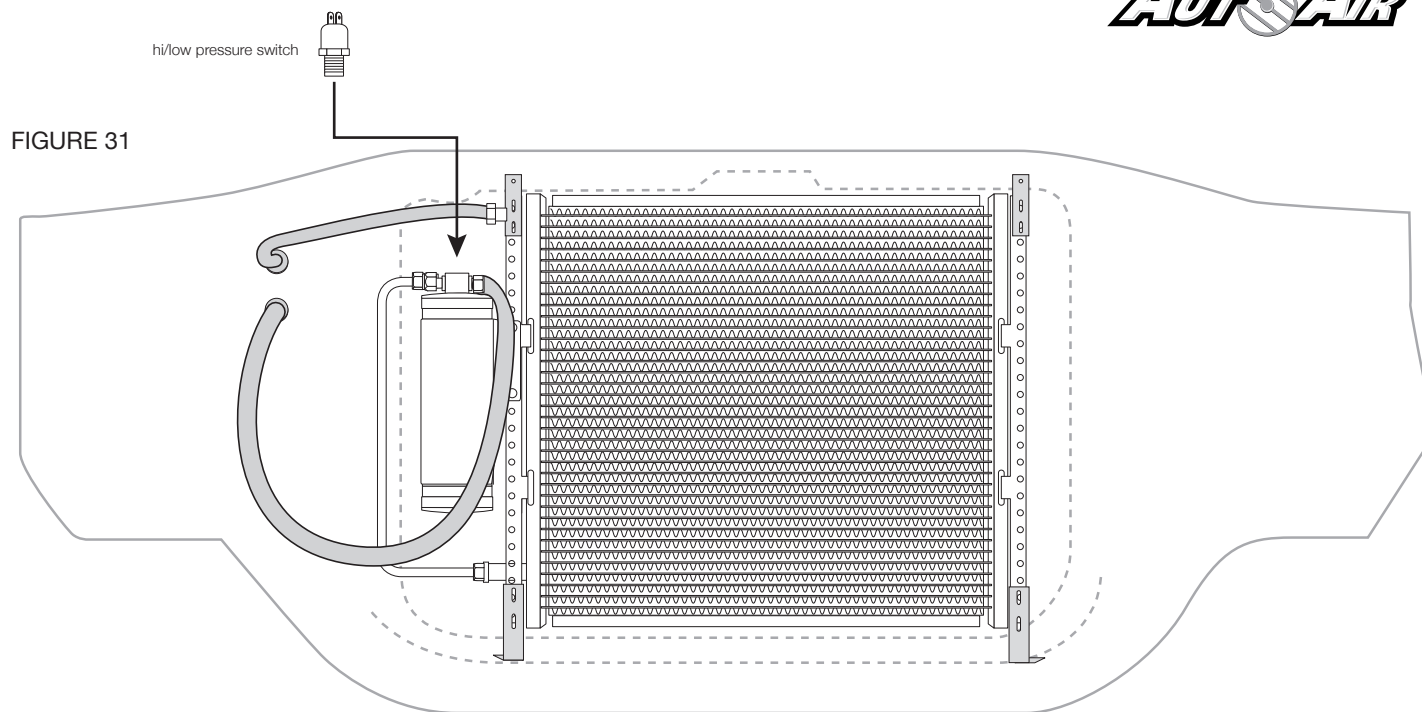

Locate the liquid hose and one #6 o-ring. Attach liquid hose to the drier using one #6 o-ring and few drops of lubricating oil. Route thru lower hole you drilled in the support and route to connection on firewall using o-ring and supplied lubricating oil.

Locate the discharge hose and one #8 o-ring. Attach discharge hose to the condenser using one #8 o-ring and few drops of lubricating oil. Route thru upper hole you drilled in the support and route to connection on compressor using o-ring and supplied lubricating oil.

PRESSURE SWITCH: Screw the high-pressure switch into the port on the top of the drier (see figure 31). Go ahead and plug the pressure switch harness into the switch at this time (black electrical boot with two long white wires).

Route the two white wires through the grommet along with #6 refrigerant hose. One of the wires attaches to blue clutch wire from thermostat and the other to the compressor clutch.



Reminder...
Use two
wrenches to
tighten o-ring
fittings

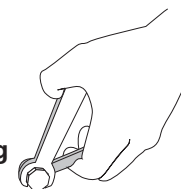

Connecting the Hoses

Install the compressor kit. Included was a premium compressor kit with all the parts you'll need to install the compressor. This kit includes instructions specifically written for your engine. Once you've installed the complete compressor kit, continue on to connecting the hoses.

CONNECTING THE HOSES:

Based on PASSENGER or DRIVERS SIDE compressor mounting see illustrations for routing.

The #10 (**LARGEST**) refrigerant hose. Attach end with service fitting to the compressor using (1) #10 o-ring and a few drops of mineral oil. Attach other end to #10 fitting at the firewall. Attach using one #10 o-ring and a few drops of mineral oil. Tighten securely.

The #6 (**SMALLEST**) refrigerant hose. Route behind fender and to the connection on firewall. Attach using two #6 o-ring and a few drops of mineral oil.

The #8 (**MEDIUM**) refrigerant Hose. Route across engine and to the connection on compressor. Attach using two #8 o-ring and a few drops of mineral oil.

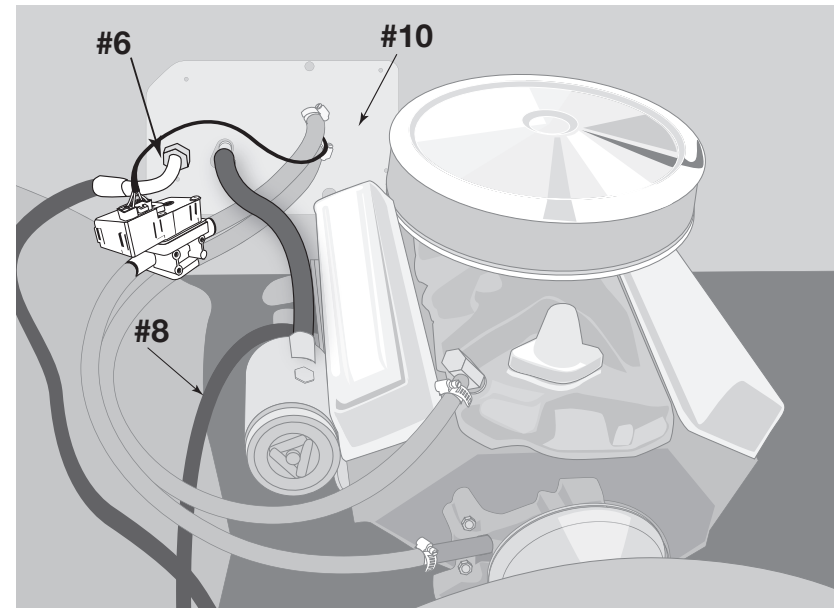

PASSENGER SIDE

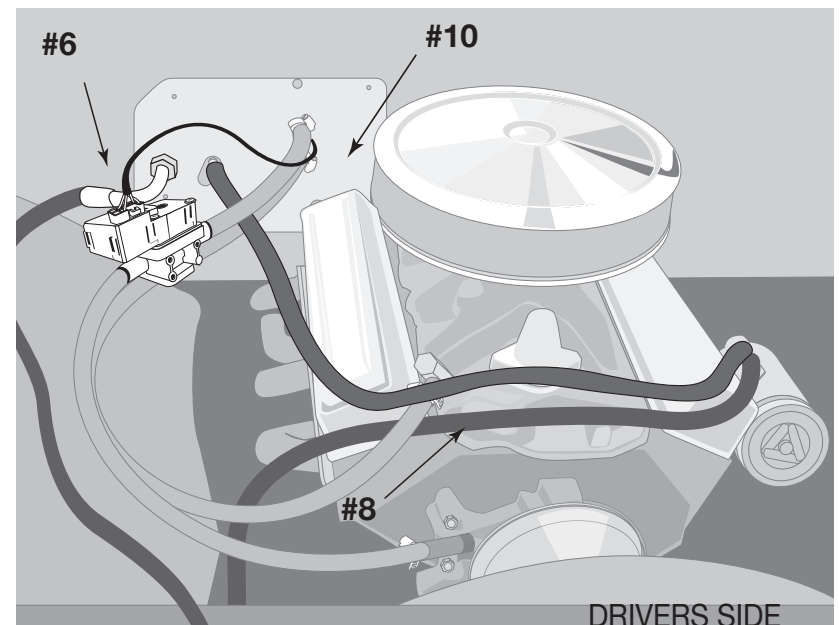

DRIVERS SIDE

TWO WRENCH METHOD

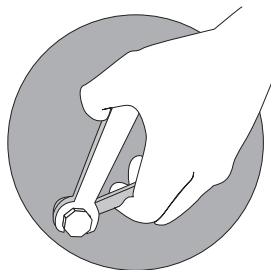

Reminder...
Use two
wrenches to
tighten o-ring
fittings



FINAL STEPS: Take a look around at your installation and check all fittings and bolts for tightness, check the heater hose clamps for tightness, and make sure nothing is routed in a way to obstruct any moving parts. **You can refill the radiator and reconnect the battery at this time.**

**WAY TO GO! You've just completed the installation of your new A/C system.
The very final step is to fully charge and test your new system.**

**On the next page you'll find specifications for proper final preparation
for your A/C technician.**

New A/C System Preparation... A MUST READ!



Please read through these procedures before completing this new A/C system charging operation.

A licensed A/C technician should be utilized for these procedures to ensure that your new system will perform at it's peak, and that your compressor will not be damaged.

1. Your radiator/cooling system is an integral part of your new system. Please insure that you have a 50/50 mix of distilled water and antifreeze. The heater coil **MUST** be purged (cycle heater control valve) to make sure no water, without antifreeze, is in the heater coil before you charge the A/C system.
2. Evacuate the system for a minimum of 45 minutes.
3. Your new compressor **MUST** be hand turned 15-20 revolutions before and after charging with liquid. Failure to do this may cause the reed valves to become damaged. This damage is **NOT** covered by your warranty.
4. Your new system requires 1.5lbs (24oz) of R134a refrigerant.
5. Your new compressor comes charged with oil - **NO** additional oil is necessary.
6. Ensure that the new belt is tight.
7. **DO NOT** charge system with liquid refrigerant!



Recommended Test Conditions:

(After system has been fully charged and tested for basic operation)

- Determine the temperature outside of the car
- Connect gauges or service equipment to high/low charging ports
- Place blower fan switch on medium
- Close all doors and windows on vehicle
- Place shop fan directly in front of condenser
- Run engine idle up to approximately 1500 rpm

ACCEPTABLE OPERATING PRESSURE RANGES:

1. High-side pressures: 150-275 PSI
2. Low-side pressures: 10-25 PSI(in a steady state)

Readings above are based on an ambient temperature of 90° with an adequate airflow on condenser.

CAUTION! When mounting your compressor and/or adjusting the belt use caution. Mount by using the centerline of the oil fill plug as your guide. The compressor can **ONLY** be mounted inbetween the 9 to 3 positions. DO NOT mount inbetween the 4 to 8 positions.

This can cause compressor failure.

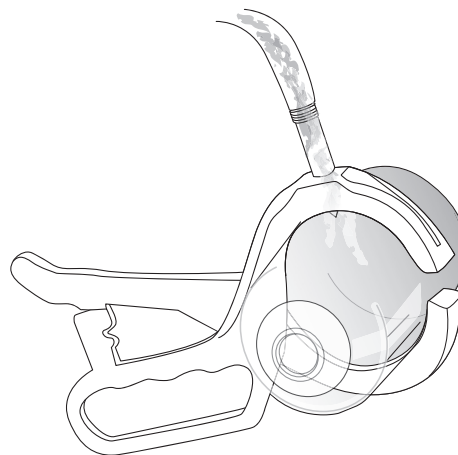

CENTERLINE OF THE OIL FILL BOLT

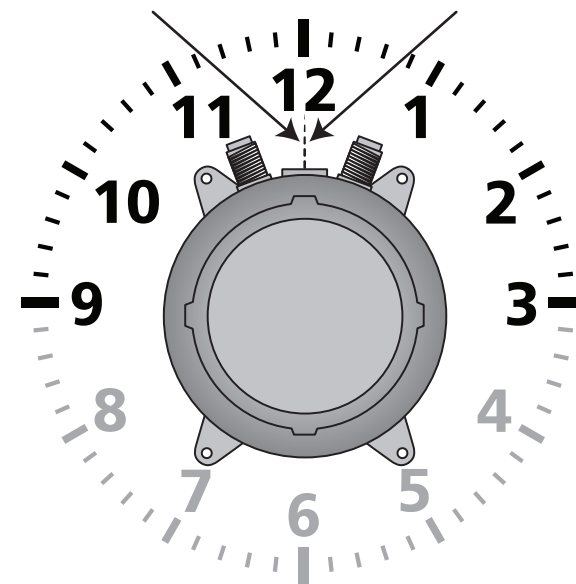

Do **NOT** tilt, shake or turn refrigerant can upside-down OR use a charging station to install refrigerant while the engine is running. Doing so will direct liquid refrigerant into the compressor piston chamber, causing damage to reed valves and/or pistons and/or other components, as well as potentially seizing the compressor. Allow a minimum of 30 minutes for liquid to "boil off." You must hand turn the compressor hub (not the pulley) a minimum of 15 complete revolutions prior to starting the engine with the clutch engaged.

Troubleshooting Guide

Test conditions used to determine system operation:

These test conditions will simulate the effect of driving the vehicle and give the technician the three critical readings that they will need to diagnose any potential problems.

- A. Connect gauges or service equipment to high/low charging ports
- B. Place blower fan switch on medium
- C. Close all doors and windows on vehicle
- D. Place shop fan in front of condenser
- E. Run engine idle up to 1500 RPM

Acceptable operating pressure ranges (R134A type):

1. High-side pressures: 150-275 PSI

*note: general rule is two times the ambient/daytime temperature plus 15-20%

2. Low-side pressures: 10-25 PSI in steady state

Charge as follows: R134a = 1.5lbs (24oz)

No additional oil is necessary in our new compressors.

Typical problems encountered in charging systems - noisy compressor:

A noisy compressor is generally caused by charging a compressor with liquid or overcharging.

A. If the system is overcharged both gauges will read abnormally high readings. This is causing a feedback pressure on the compressor causing it to rattle or shake from the increased cylinder head pressures. System must be evacuated and re-charged to exact weight specifications.

B. Installing the heater control valve in the incorrect hose will cause the system to cool at idle and gradually warm up when the RPM's of the engine rise. The heater control is a directional valve; make sure the water flow is with the direction of the arrow. As the engine heats up, the water transfers the heat to the coil thus overpowering the a/c coil. A leaking or faulty valve will have a more pronounced affect on the unit's cooling ability. Installing the valve improperly - such as having the flow reversed - will also allow water to flow through which inhibits the cooling. Check for heat transfer by disconnecting hoses from the system completely. By running down the road with the hoses looped backed through the motor you eliminate the possibility of heat transfer to the unit.

C. Evaporator freezing can occur both externally and internally on an evaporator core. External freeze up occurs when the coil can't effectively displace the condensation on the outside fins so the water forms ice. The evaporator core resembles a block of solid ice, it restricts the flow of air that can pass through it, which gives the illusion of the air not functioning. The most common cause of external freezing is the thermostat setting and humidity in the passenger compartment. All door and window seals should be checked in the event of constant freeze-up. A thermostat is provided with all units to control the cycling of the compressor.

D. Internal freeze-up occurs when the system has too much moisture inside. The symptoms of internal freeze-up often surface after extended highway driving. The volume of air stays constant but the temperature of the air gradually rises. When this freezing occurs the low-side pressure will drop and eventually go into a vacuum. At this point, the system should be checked by a professional who will evacuate the system and change the drier.

E. The condenser works best in front of the radiator with a large supply of fresh air. Abnormally high pressures will result from improper airflow. Check the airflow requirements by placing a large capacity fan in front of the condenser and running cool water over the surface. Pressures dropping significantly will indicate the need for better airflow.

F. Incorrect condenser capacity will cause abnormally high head pressures. A quick test that can be performed is to run cool water over the condenser while the system is operating, if the pressures decrease significantly, it is likely a airflow or capacity problem.

G. An expansion valve failure is generally caused by dirt or debris entering the system during assembly. If an expansion valve fails it will be indicated by abnormal gauge readings. A valve that is blocked will be indicated by high-side that is unusually high and the low-side unusually low (may even go into a vacuum.) A valve that is stuck open will be indicated by both the pressures rising to unusually high readings and tend to move toward equal readings on the gauges.

H. A restriction in the cooling system will cause abnormal readings on the gauges. A high-side restriction, between the compressor and the drier inlet, will be indicated by the excessively high discharge reading. These simple tests can be performed by a local shop and can help determine the extent of the system's problem.



Troubleshooting Your Classic Auto Air A/C System

Problem: system is not cooling properly

Issue: cold at idle. warmer when raising engine RPMs

Make sure the water valve is positioned correctly.

The water valve is a directional valve and should be installed with the arrow pointing towards the water pump. It should be connected to the heater hose that runs from the heater core to the water pump. If the water valve is incorrectly connected to the hose it allows water to circulate through the system via the heater core over-powering the cooling effect of the a/c coil.

Step 1: Check placement of the water valve and correct if needed.

Step 2: If changing the location of the water valve does not rectify the issue, the water valve may be permanently damaged and may need to be replaced. To check the integrity of the water valve you will need to completely remove the heater core's water hoses and "loop" together. By doing so, the heater system will be completely removed from the possibilities. If the system now cools then the water valve will need to be replaced.

Verify adequate air flow to the condenser.

The condenser's function is to dissipate heat. Your air conditioning system will not cool your vehicle's cabin properly if you do not have an adequate airflow across the condenser.

Step 1: Connect gauges to a/c hoses. When ambient temp is 90°, pressures should be:

Low-side pressures: 10-25 PSI

High-side pressures: 150-275 PSI

If the low-side pressures are normal but the high-side pressures are high then there might be an airflow issue and you will need to test the airflow to the condenser.

Test airflow to the condenser.

Step 1: Place a piece of paper on the condenser with the car idling to see if the paper is held in place.

Step 2: With the car still idling, attach gauges and place a large capacity fan in front of the condenser. Check the pressures to see what happens.

Step 3: With the car still idling and the gauges still attached, pour water down the front of the condenser. Check the pressures again to see what happens.

If the paper was held in place then you are getting some air flow. If the high-side decreases during step 2 and step 3 then your condenser is not getting enough air which is stopping your system from cooling properly. To correct this issue, you will need a more powerful mechanical fan.

Confirm the correct refrigerant charge is in the system.

All of our systems should be charged with 1.5lbs (24oz) of R134a refrigerant only. If overcharged, you will need to evacuate the system and recharge with the correct amount.*

Measurement meanings:

1. Low temp and high pressure seems to be equal = malfunctioning expansion valve that is stuck open.
2. High side is extremely high and low side is extremely low (possibly into vacuum) = blockage in the system. Remove hoses and blow cold compressed air through it in both directions. Re-check your pressures. If pressures do not change then it is possible that your expansion valve is stuck closed and would have to be replaced.

***Compressor Concerns:**

If you have a noisy compressor, it is due to the improper charging with liquid or overcharging. An overcharged compressor will cause rattling. A compressor charged with pure liquid produces a high probability of bent reed valves. When the reed valves get bent they will create a tapping sound. Ensure your system is charged with 1.5lbs (24oz) of R134a refrigerant to avoid compressor related cooling issues.

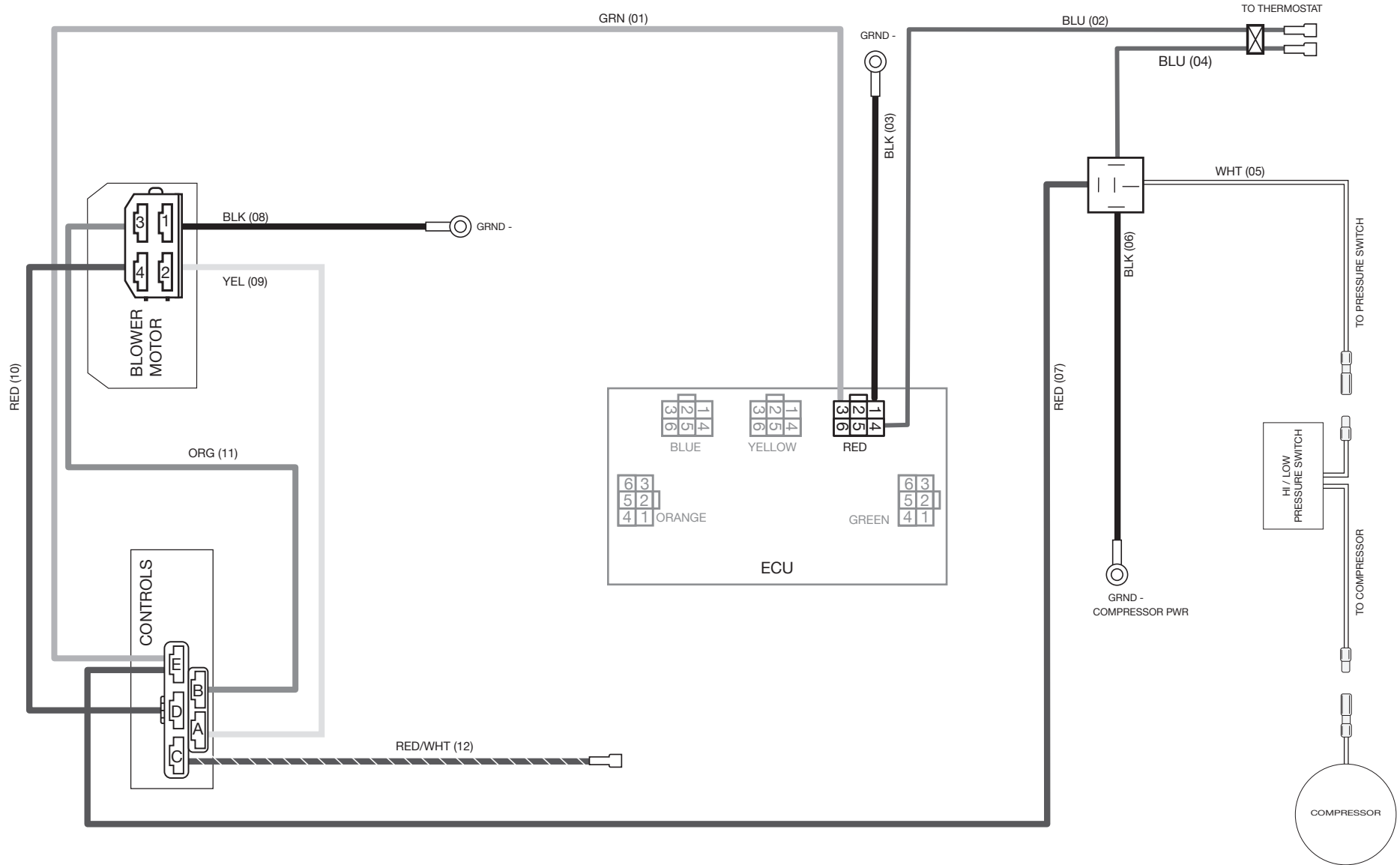

Wiring Schematic / REVERSE

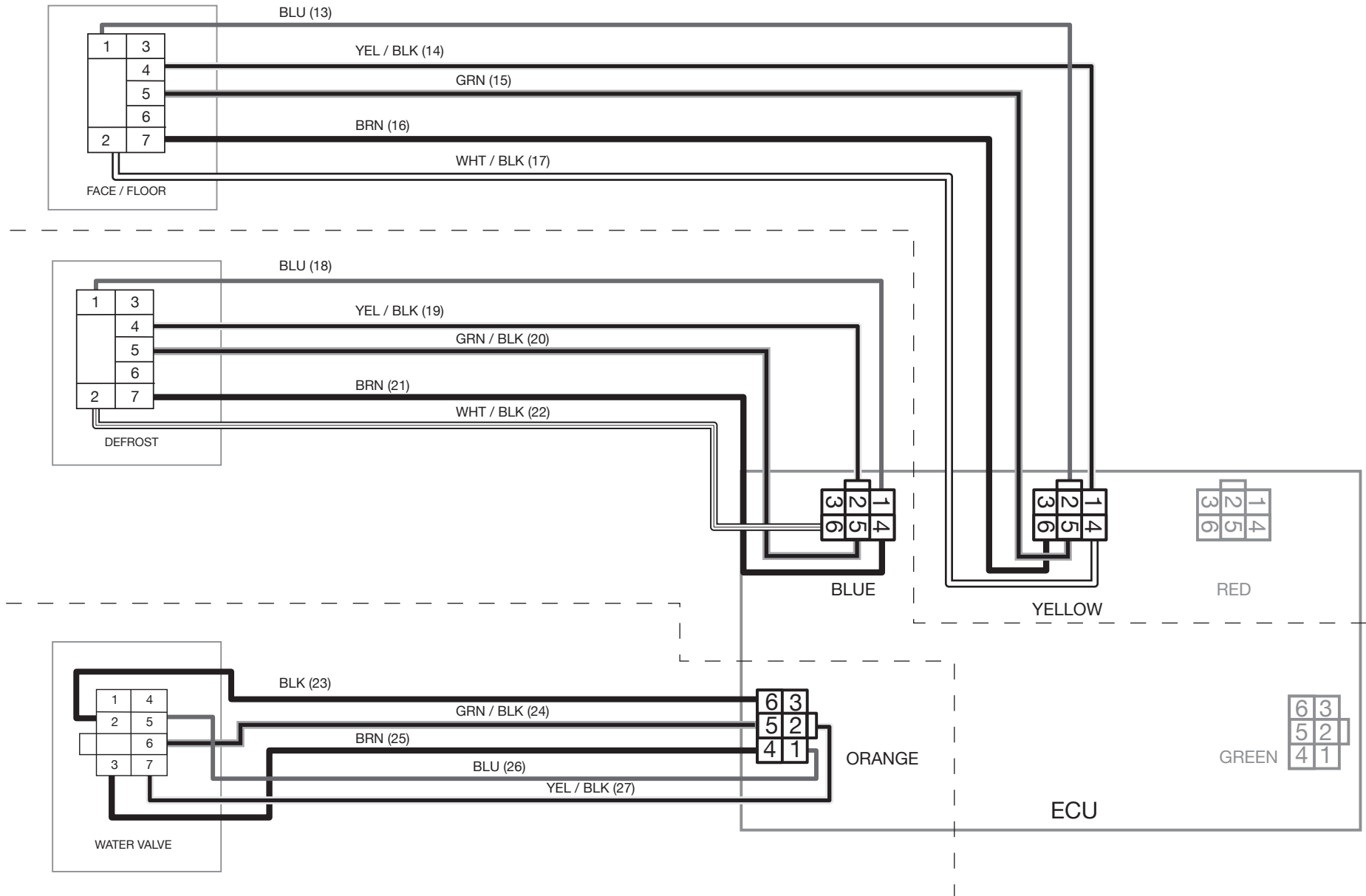

ALIGN WITH EDGE OF DEFROST DUCT

Template Right Side Defrost

CUT EDGE



IF YOU PRINTED THIS MANUAL
PLEASE READ THIS...
Just as a cautionary step, please
measure this box and make sure it
is 1" x 1". Some copiers/printers
may not print at 100% of actual size.

IF YOU PRINTED THIS MANUAL
PLEASE READ THIS...
Just as a cautionary step, please
measure this box and make sure it
is 1" x 1". Some copiers/printers
may not print at 100% of actual size.



GM PART NUMBER
3906067

Template LEFT Side Defrost
1968 Chevelle

WT LINE

ALIGN WITH
HOLE

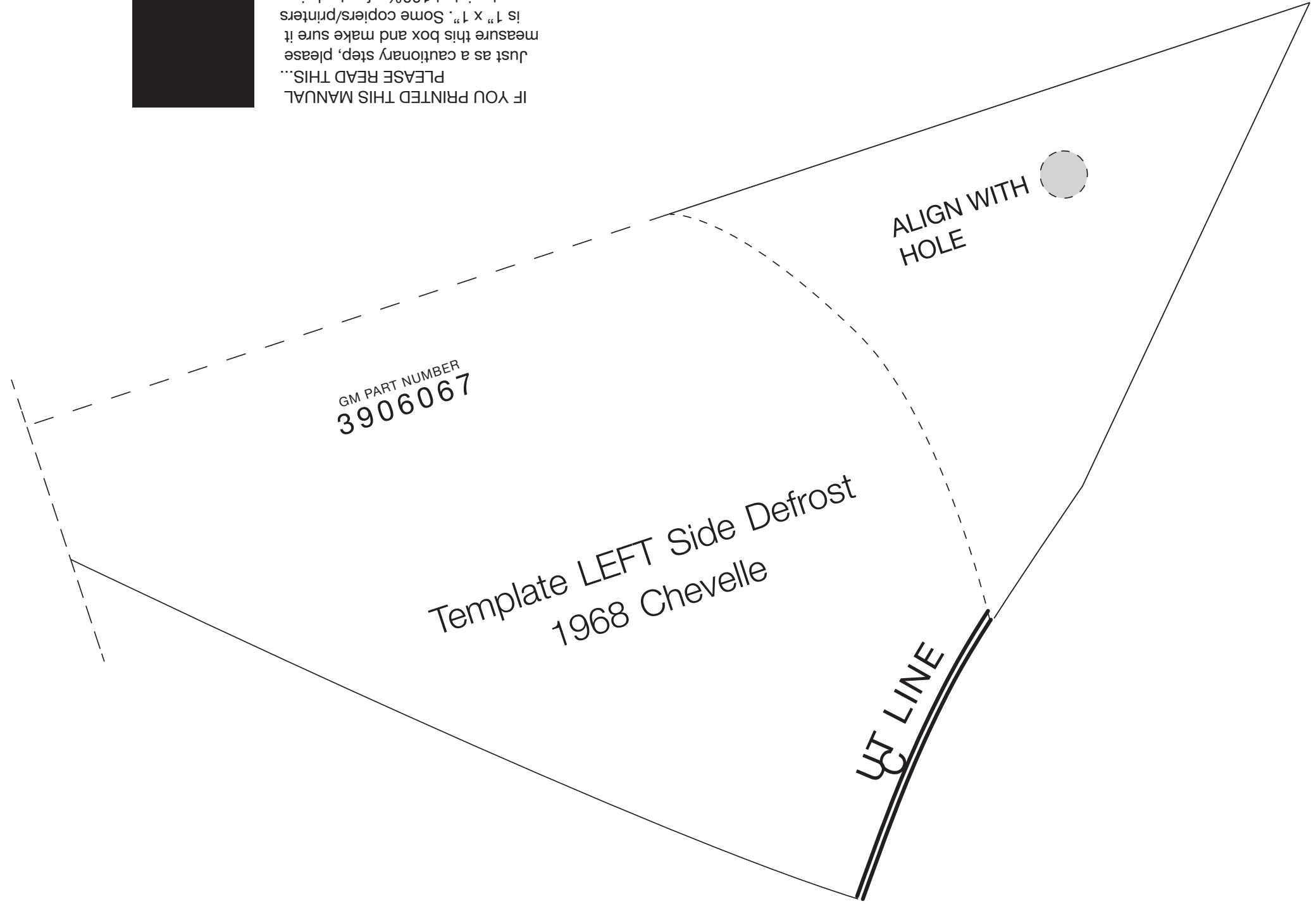



DRILL
1/4" DIA.
HOLE

OEM OPENING

IF YOU PRINTED THIS MANUAL
PLEASE READ THIS...
Just as a cautionary step, please
measure this box and make sure it
is 1" x 1". Some copiers/printers
may not print at 100% of actual size.



IF YOU PRINTED THIS MANUAL
PLEASE READ THIS...
Just as a cautionary step, please
measure this box and make sure it
is 1" x 1". Some copiers/printers
may not print at 100% of actual size.



DRILL
1 3/8" DIA.
HOLE

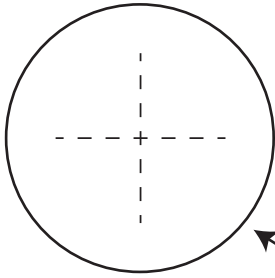

DRILL
1" DIA.
HOLE

